

Jacuzzi J-135

Specifications

Seating Capacity	6 Adults
Dimensions	84" x 84" x 36" (213.5 cm x 213.5 cm x 91.5 cm); For Complete Dimensions, See page 99
Dry Weight	718 lbs (326 kg)
Filled Weight (Spa Volume)	4,554 lbs (2,066 kg)
Filled Weight (Average Fill)	3,720 lbs (1,688 kg)
Water Capacity (Spa Volume) ...	460 US gallons (1,741 Liters)
Water Capacity (Average Fill) ...	360 US gallons (1,363 Liters)
Electronic Controls	Solid state electronic controls with LED readout, programmable temperature, filtration, and heat cycles
Pump 1	North America (60 Hz): 2-Speed, 4.5 HP brake, 2.5 HP continuous, 56 Frame Export (50 Hz): 2-Speed, 2.0 HP continuous
Pump 2	North America (60 Hz): 1-Speed, 4.8 HP brake, 2.5 HP continuous, 56 Frame Export (50 Hz): 1-Speed, 2.0 HP continuous
Circulation Pump	No
Total Jets	35
Seat A Jets	6 Classic Euro, 4 Classic Pulsator, 2 Classic Luxury
Seat B Jets	2 Classic Turbo
Seat C Jets	6 Classic Euro, 2 Classic Luxury
Seat D Jets	1 Classic Luxury
Seat E Jets	4 Classic Direct, 2 Classic Luxury
Seat F Jets	3 Classic Mini
Footwell (G)	3 Classic Luxury
Massage Selectors	None
Air Controls	3
Water Management System	One 50 ft ² filter cartridge on jets pump 1
LED Lighting	Classic LED lighting package of 6 lights
Synthetic Cabinet Colors	Silverwood and Roasted Chestnut
Acrylic Colors	Platinum and Silver Pearl
Headrests	3
Electrical Requirements:	North America (60 Hz): 240 VAC@40A/50A or 60A Export (50 Hz): 230-240 VAC@20A/30A or 40A, or suitably rated circuit breaker to comply with local electrical codes. Certain countries may require dual power inputs; two GFCI RCD breakers are required for this configuration.
Warranty*	North America (60 Hz): 5 Years Shell, 2 Years Shell Surface, 2 Years Plumbing Component Leaks, 2 Years Equipment and Controls; 1 Year Cabinet, 1 Year Jets Export (50 Hz): 5 Years Shell, 2 Years Shell Surface, 2 Years Plumbing Component Leaks, 2 Years Equipment and Controls, 1 Year Cabinet, 1 Year Jets
Audio System (Optional)	Not Available

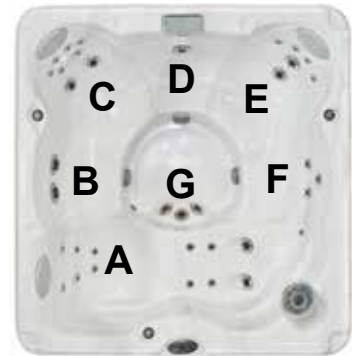

*(See Warranty Document for Specific Details)

Dimensions/Specifications are Subject to Change Without Notice

Jacuzzi J-135

Massage Selector/Air Control Diagram



Air Control 2:
Opens/Closes
Air Inlet to Jets C

Air Control 3:
Opens/Closes
Air Inlet to
Jets E and G

Group A, B, D, and F jets
always on when jets
pump 1 is running.

Group C, E, and G jets
always on when jets
pump 2 is running.

Waterfall is always
on when jets pump
1 is running, but
can be turned off
at the waterfall.

Air Control 1:
Opens/Closes
Air Inlet to Jets
A, B, D, and F

35 Total Jets



Classic
Euro
Jets (12)



Classic
Direct
Jets (4)



Classic
Pulsator
Jets (4)



Classic
Mini
Jets (3)



Classic
Luxury
Jets (10)



Classic
Turbo
Jets (2)

Spa Operation Subject to Change without Notice

Seat Depths

A = 25.75" (65.4 cm)

G = 32.00" (81.3 cm)

Listed dimensions
represent distance from
top of acrylic to lowest
point in seat. Tolerance
 $\pm 0.5"$ (1.27 cm).

B = 25.00" (63.5 cm)

C = 26.50" (67.3 cm)

D = 22.00" (55.9 cm)

E = 25.25" (64.1 cm)

F = 24.00" (60.9 cm)

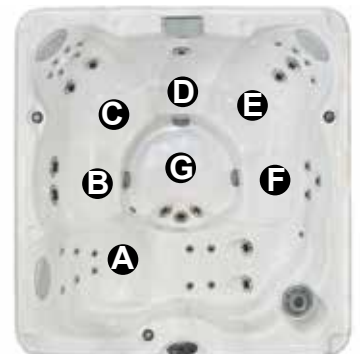

Dimensions/Specifications are Subject to Change Without Notice

Jacuzzi J-135

Dimensions

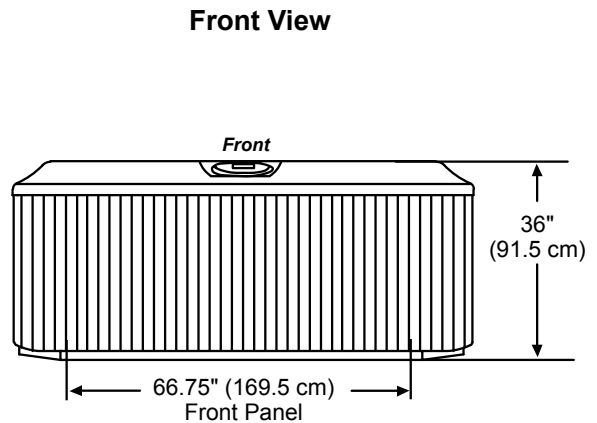
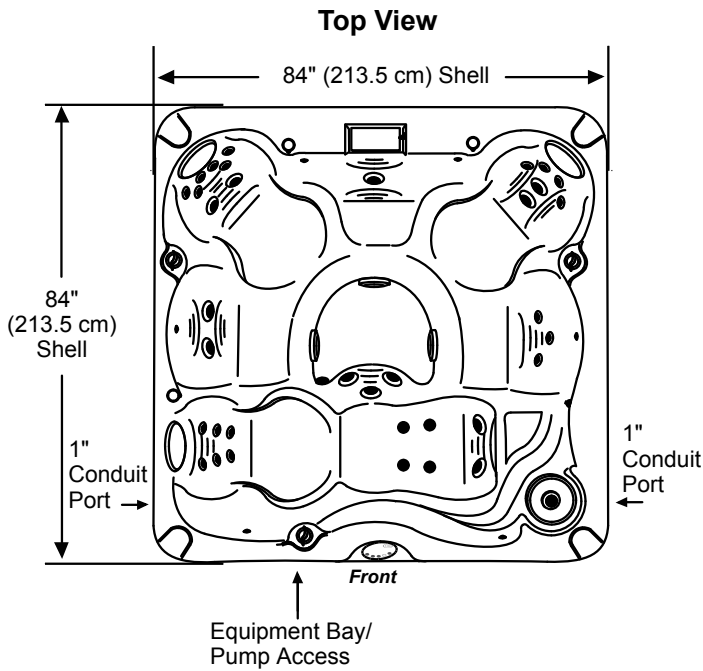

Equipment Access Panel (Spa Drain Hose Located Behind Front Panel)

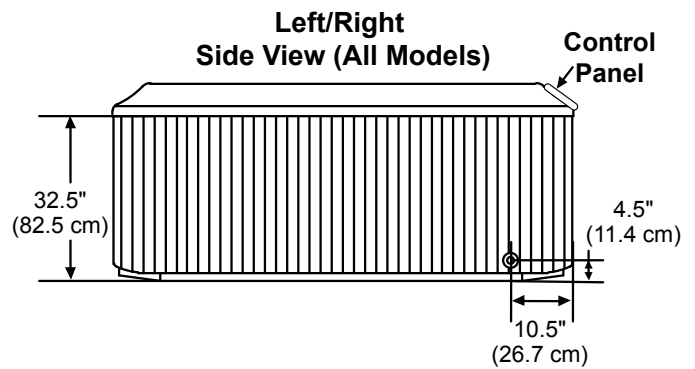

IMPORTANT! Always measure each hot tub for exact dimensions BEFORE designing its foundational support and/or decking.

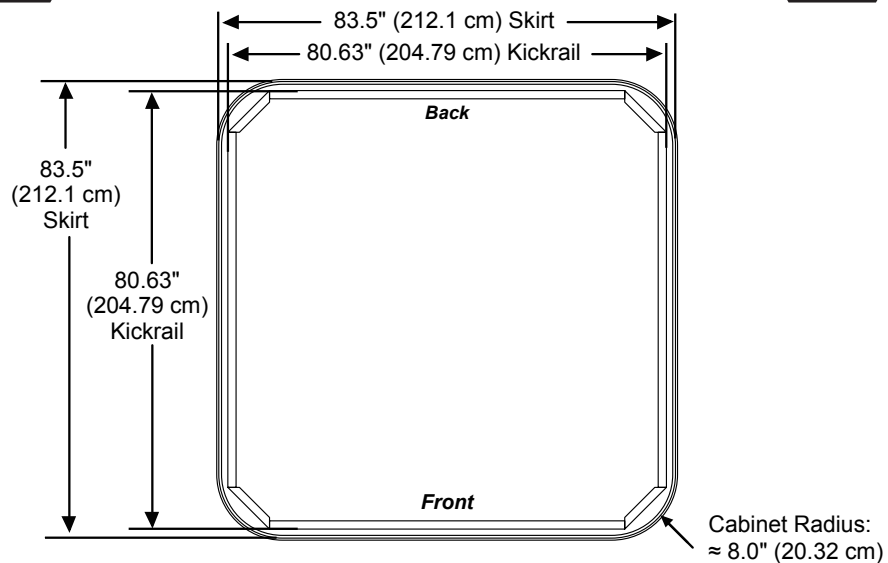

Dimensions/specifications subject to change without notice. Tolerance $\pm 0.5"$ (1.27 cm)