

# Spa Owner's Manual

To Call for Technical Assistance:  
(866) 245-3387

For Blue Ridge Spas  
Havencrest, Windsor, Winchester and Richmond Models

**IMPORTANT!**

*Take This Time to Register Your Spa.*

**Owner's Record**

Date Purchased

---

Purchased From

---

Installed By

---

Date

---

Spa Serial Number\*

---

Model Number\*

---

*\* The spa serial number and model number are written on a sticker attached to the electrical control box.*

## Table of Contents

Important Hot Tub Owner Information.....	6
Important Safety Instructions .....	7
Locating Your Hot Tub.....	11
General Electrical Safety Instructions .....	12
Equipment Bay / Wiring Figures A-C .....	13
Electrical Installation Instructions (240 VAC) .....	14
Power Supply Options and Requirements .....	15
Start Up Instructions.....	15
Control Panel.....	17
Warmer and Cooler Buttons .....	17
Light Button .....	18
Jets 1 Button .....	18
Jets 2 Button .....	18
Initial Start Up.....	19
Selecting Filter Cycles .....	19
Filtration .....	19
Filter Cycles.....	20
Standard Mode .....	20
Economy Mode.....	21
Care and Maintenance of Your Hot Tub .....	21
Cleaning the Filters .....	22
Ozonators .....	22
Draining and Refilling .....	22
Cleaning the Hot Tub Surface .....	23
Maintaining the Synthetic Cabinet.....	23

- Maintaining the Cover ..... 23
- Winterizing ..... 24
- Restarting Your Hot Tub in Cold Weather ..... 25
  
- Maintaining Water Quality ..... 25
  - pH Control ..... 25
  - Sanitizing ..... 25
  
- Other additives ..... 26
  - Water sanitization with ozone ..... 26
  
- Troubleshooting ..... 27
  
- Troubleshooting Procedures ..... 28
  - Problem - Procedure ..... 28
  - Pump priming instructions ..... 28
  
- Wiring Diagram (50Hz) ..... 30

## Important Hot Tub Owner Information

Your hot tub is constructed to the highest standards and is capable of providing many years of trouble-free use. However, because heat retentive materials are utilized to insulate the hot tub for efficient operation, an uncovered hot tub surface directly exposed to sunlight and high temperatures for an extended period is subject to permanent damage. Damage caused by exposing the hot tub to this abuse is not covered by warranty. We recommend that you always keep the hot tub full of water when it is exposed to direct sunlight and that you keep the insulating cover in place at all times when the hot tub is not in use. Read and carefully follow the requirements for your hot tub's support base (found in the section titled, "Locating Your Hot Tub", page 10).

Blue Ridge Spas constantly strives to offer the finest hot tub available, therefore modifications and enhancements may be made which affect the specifications, illustrations and/or instructions contained herein.

### FCC Notice

This equipment has been tested and found to comply with the limits for a Class B Digital Device, pursuant to Part 15 of the FCC Rules. These limits are designed to provide reasonable protection against harmful interference in a residential installation. This equipment generates, uses and can radiate radio frequency energy and, if not installed and used in accordance with the instructions, may cause harmful interference to radio communications. However, there is no guarantee that interference will not occur in a particular installation. If this equipment does cause harmful interference to radio or television reception, which can be determined by turning the equipment off and on, the user is encouraged to try to correct the interference by one or more of the following measures: 1) Rearrange or relocate the receiving antenna. 2) Increase the separation between the equipment and receiver. 3) Connect the equipment into an outlet on a circuit different from the circuit connected. 4) Consult the dealer or an experienced radio/TV technician for help. Changes or modifications not expressly approved by the party responsible for FCC compliance could void the user's authority to operate this equipment.

## IMPORTANT SAFETY INSTRUCTIONS: READ AND FOLLOW ALL INSTRUCTIONS CAREFULLY

When installing and using this electrical equipment, basic safety precautions should always be followed, including:

- 1) **WARNING:** To reduce the risk of injury, do not permit children to use this product unless they are closely supervised at all times.
- 2) **WARNING:** A grounding wire connector is provided on this unit to connect a minimum No. 8AWG (8.4mm<sup>2</sup>) solid copper conductor between this unit and any metal equipment, metal enclosures of electrical equipment, metal water pipe, or conduit within 5 feet (1.5m) of the unit.
- 3) **DANGER:** Risk of Accidental Drowning. Extreme caution must be exercised to prevent unauthorized access by children. To avoid accidents, ensure that children cannot use this hot tub unless they are supervised at all times.
- 4) **DANGER:** Risk of Injury. The suction fittings in this hot tub are sized to match the specific water flow created by the pump. Should the need arise to replace the suction fittings or the pump, be sure that the flow rates are compatible. Never operate the hot tub if the suction fittings are broken or missing. Never replace a suction fitting with one rated less than the flow rate marked on the original suction fitting.
- 5) **DANGER:** Risk of Electric Shock. Install at least 5 feet (1.5m), from all metal surfaces. As an alternative, a hot tub may be installed within 5 feet (1.5m) of metal surfaces if each metal surface is permanently connected (bonded) by a minimum No. 8 AWG (8.4 mm<sup>2</sup>) solid copper conductor attached to the wire connector on the grounding lug, inside the equipment compartment on the equipment box.
- 6) **DANGER:** Risk of Electric Shock. Do not permit any electrical appliance, such as a light, telephone, radio, television, etc. within 5 feet (1.5m) of a hot tub.
- 7) **ELECTRICAL SUPPLY:** The electrical supply for this product must include a suitably rated switch or circuit breaker to open all ungrounded supply conductors to comply with section 422-20 of the National Electrical Code, ANSI/NFPA 70. The disconnect must be readily accessible and visible to the hot tub occupant but installed at least 5

feet (1.5m), from the hot tub water.

8) **WARNING: To Reduce the Risk of Injury:**

- a) The water in a hot tub should never exceed 104°F (40°C). Water temperatures between 100°F (38°C) and 104°F (40°C) are considered safe for a healthy adult. Lower water temperatures are recommended for young children and when hot tub use exceeds 10 minutes.
- b) Since excessive water temperatures have a high potential for causing fetal damage during the early months of pregnancy, pregnant or possibly pregnant women should limit hot tub water temperatures to 100°F (38°C). If pregnant, please consult your physician before using a hot tub.
- c) Before entering the hot tub, the user should measure the water temperature with an accurate thermometer since the tolerance of water temperature regulating devices may vary as much as +/- 5°F (2°C).
- d) The use of alcohol, drugs, or medication before or during hot tub use may lead to unconsciousness with the possibility of drowning.
- e) Persons suffering from obesity or a medical history of heart disease, low or high blood pressure, circulatory system problems, or diabetes should consult a physician before using a hot tub.
- f) Persons using medication should consult a physician before using a hot tub since some medication may induce drowsiness, while other medication may affect heart rate, blood pressure, and circulation.

## IMPORTANT SAFETY INSTRUCTIONS

### CANADIAN STANDARDS ASSOCIATION (CSA) SAFETY INFORMATION

When using this electrical equipment, basic safety precautions should always be followed, including the following:

- a) **READ AND FOLLOW ALL INSTRUCTIONS.**
- b) A green colored terminal or a terminal marked G, Gr, Ground, Grounding or the  symbol\* is located inside the supply terminal box or compartment. To reduce the risk of electric shock, this terminal must be connected to the grounding means provided

in the electric supply service panel with a continuous copper wire equivalent in size to the circuit conductors that supply this equipment.

IEC Publication 417, Symbol 5019.

- c) At least two lugs marked "Bonding Lugs" are provided on the external surface or on the inside of the supply terminal box/compartiment. To reduce the risk of electric shock, connect the local common bonding grid in the area of the hot tub to these terminals with an insulated or bare copper conductor not smaller than No. 6 AWG.
- d) All field-installed metal components such as rails, ladders, drains or other similar hardware within 10 feet (3m) of the hot tub shall be bonded to the equipment grounding buss with copper conductors not smaller than No. 6 AWG.
- e) **SAVE THESE INSTRUCTIONS.**

**WARNING:** Children should not use hot tubs without adult supervision.

**WARNING:** Do not use hot tubs unless all suction guards are installed to prevent body and hair entrapment.

**WARNING:** People with infectious diseases should not use a hot tub.

**WARNING:** To avoid injury, exercise care when entering or exiting the hot tub.

**WARNING:** Do not use drugs or alcohol before or during the use of a hot tub to avoid unconsciousness and possible drowning.

**WARNING:** Pregnant or possibly pregnant women should consult a physician before using a hot tub.

**WARNING:** Water temperature in excess of 100°F (38°C) may be injurious to your health.

**WARNING:** Before entering the hot tub, measure the water temperature with an accurate thermometer.

**WARNING:** Do not use a hot tub immediately following strenuous exercise.

**WARNING:** Prolonged immersion in a hot tub may be injurious to your health.



WARNING: Do not permit electric appliances (such as light, telephone, radio, television, etc.) within 5 feet (1.5m) of this hot tub.

CAUTION: Maintain water chemistry in accordance with manufacturer's instructions.

WARNING: The use of alcohol or drugs can greatly increase the risk of fatal hyperthermia in hot tubs.

## SAVE THESE INSTRUCTIONS HYPERTHERMIA

Prolonged immersion in hot water may induce hyperthermia. A description of the causes, symptoms, and effects of hyperthermia are as follows:

Hyperthermia occurs when the internal temperature of the body reaches a level several degrees above the normal body temperature of 98.6°F (37°C). The symptoms of hyperthermia include drowsiness, lethargy, and an increase in the internal temperature of the body. The effects of hyperthermia include:

- a) Unawareness of impending hazard;
- b) Failure to perceive heat;
- c) Failure to recognize the need to exit hot tub;
- d) Physical inability to exit hot tub;
- e) Fetal damage in pregnant women; and
- f) Unconsciousness and danger of drowning.

### Cautions

1. Persons suffering from heart disease, diabetes, high or low blood pressure, and any condition requiring medical treatment, pregnant women, the elderly, or infants should consult with a physician before using a hot tub.
2. The Consumer Products Safety Commission has stated that the water temperature in a hot tub should not exceed 104°F (40°C). Immersion in water in excess of 104°F (40°C) can be hazardous to your health.
3. Observe a reasonable time limit when using the hot tub. Long exposures at higher temperatures can cause high body temperature. Symptoms may include dizziness, nausea, fainting, drowsiness, and reduced awareness. These effects could possibly result in drowning.

4. Do not use the hot tub under the influence of alcohol, narcotics, or other drugs. Use of the hot tub under these conditions may lead to serious consequences.
5. Always test the hot tub water temperature before entering the hot tub. Enter and exit the hot tub slowly. Wet surfaces can be very slippery.
6. Never bring any electrical appliances into or near the hot tub. Never operate any electrical appliances from inside the hot tub or when you are wet.
7. Proper chemical maintenance of hot tub water is necessary to maintain safe water and prevent possible damage to hot tub components.
8. Use the hot tub straps and clip tie downs to secure the cover when not in use. This will help to discourage unsupervised children from entering the hot tub and keep the hot tub cover secure in high-wind conditions. There is no representation that the cover, clip tie downs, or actual locks will prevent access to the hot tub.

## Locating Your Hot Tub

**IMPORTANT:** Because of the combined weight of the hot tub, water and users, it is extremely important that the base upon which the hot tub rests be smooth, flat, level and capable of uniformly supporting this weight, without shifting or settling, for the entire time the hot tub is in place. If the hot tub is placed on a surface which does not meet these requirements, damage to the skirt and/or the hot tub shell may result. Damage caused by improper support is not covered under warranty. It is the responsibility of the hot tub owner to assure the integrity of the support over time.

We recommend a poured, reinforced concrete slab (minimum of 4 inches thick). Wood decking is also acceptable provided it is constructed so that it meets the requirements outlined above.

The hot tub must be installed in such a manner as to provide drainage away from the hot tub. Placing the hot tub in a depression without provisions for proper drainage could allow rain, overflow and other casual water to flood the equipment and create a wet condition in which it would sit.

For hot tubs which will be recessed into a floor or deck, install so as to permit access to the equipment, either from above or below, for servicing. Make certain that there are no obstructions which would prevent removal of the cabinet side panels, especially on the side with the equipment bay doors.

In selecting the ideal outdoor location for your hot tub, we suggest that you take into consideration 1) the proximity to change area and shelter (especially in colder weather); 2) the pathway to and from your hot tub (this should be free of debris so that dirt and leaves are not easily tracked into the hot tub); 3) the closeness to trees and shrubbery (remember that leaves and birds could create extra work in keeping the hot tub clean); 4) a sheltered environment (less wind and weather exposure can result in lowered operation and maintenance costs); and 5) the overall enhancement of your environment. It is preferable not to place the hot tub under an unuttered roof overhang since run-off water will shorten the life expectancy of the hot tub cover.

For indoor installations, be certain to make provisions for proper ventilation. When the hot tub is in use, considerable amounts of moisture will escape. This can damage certain surfaces over time.

If you have any questions regarding the placement or installation of your hot tub, call (866) 245-3387.

### General Electrical Safety Instructions

Your new hot tub is equipped with the “state-of-the-art” equipment system. It contains the most advanced safety and self-protective equipment in the industry. Nonetheless, this hot tub must be installed properly to insure dependable usage. Please contact your local building department should you have any questions regarding your installation.

**Proper grounding is extremely important.** Your hot tubs is equipped with a current collector system. A pressure wire connector is provided on the surface of the control box, located inside the equipment door to permit connection of a bonding wire between this point and any ground metal equipment, metal water pipe or conduit within 5 feet (1.5m) of the hot tub, or copper clad grounding rod buried within 5 feet (1.5m) of the hot tub. Bonding wire must be at least No. 8 AWG (8.4 mm<sup>2</sup>) solid copper wire. This is a most important safety assurance feature.

Before installing this hot tub, check with the local building department to insure installation conforms to local building codes.

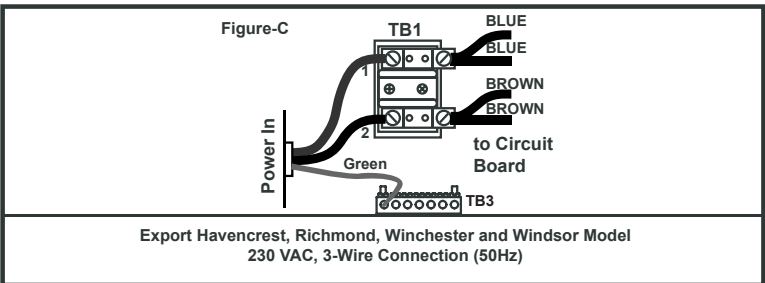
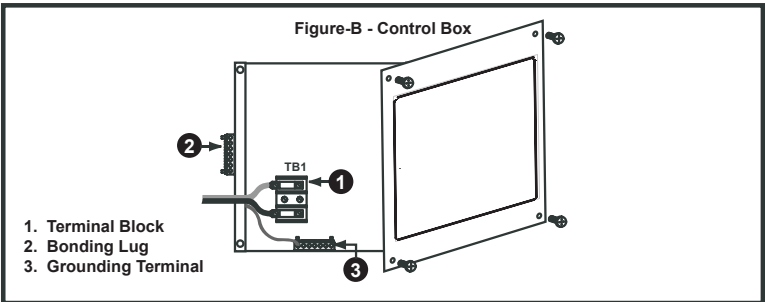
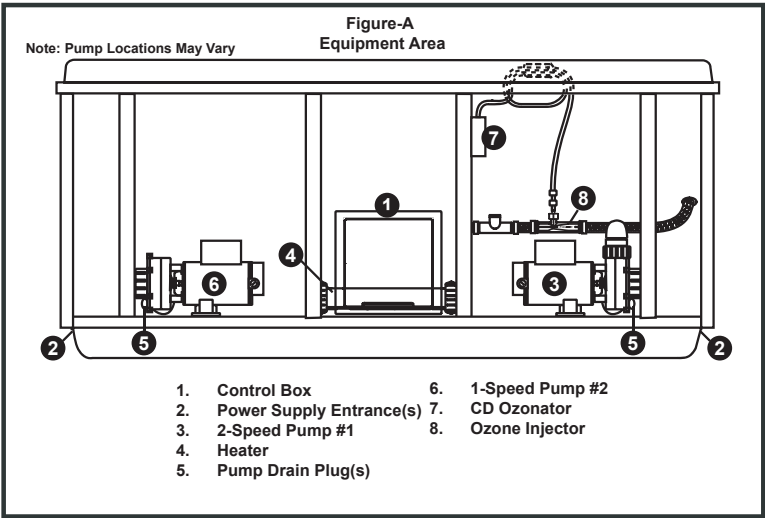

## Electrical Installation Instructions For Connection to 230V Service

**IMPORTANT NOTICE:** The electrical wiring of this hot tub must meet the requirements of the National Electrical Code (NEC) and any applicable state or local codes. The electrical circuit must be installed by a qualified electrician and approved by a local building/electrical inspection authority.

1. This hot tub must be permanently connected (hard-wired) to the power supply. No plug-in connections or extension cords are to be used in conjunction with the operation of this hot tub. Supplying power to the hot tub which is not in accordance with these instructions will void both the independent testing agency listing and the manufacturer's warranty.
2. The power supplied to this hot tub must be a dedicated circuit with no other appliances or lights sharing the power provided by the circuit.
3. To determine the current, voltage and wire size required, refer to Power Supply Options and Requirements, page 14.
  - Wire size must be appropriate per NEC and/or local codes.
  - We recommend type THHN wire.
  - All wiring must be copper to ensure proper connections. Do not use aluminum wire.
  - When using wire larger than #6, add a junction box near the hot tub and reduce to short lengths of #6 wire to connect to the hot tub.
4. The electrical supply for this product must include a suitably rated switch or circuit breaker to open all ungrounded supply conductors to comply with Section 422-20 of the National Electrical Code, ANSI/NFPA 70. The disconnecting means must be readily accessible to the hot tub's occupant but installed at least 5 feet (1.5m) from hot tub water.
5. The electrical circuit supplied for the hot tub must include a suitable ground fault circuit interruptor (GFCI) as required by NEC Article 680-42.
6. To gain access to the hot tub's power terminal block, remove the cabinet panel on the control panel side of all models. Then open the door to the control box. (Figure A, page 12).
7. Use the appropriate power supply inlet and remove the panel from the front of the hot tub to allow you to feed the cable through to the control box. Install the cable with connector through the large opening provided in the bottom of the control box.
8. Connect wires, color to color, on terminal blocks TB1 and ground (Figure C, page 12). **TIGHTEN SECURELY!** All wires must be hooked up or damage could result.
9. Close the control box door and reinstall the cabinet side panels.

## Power Supply Options and Requirements

Your hot tub is designed to provide optimum performance and flexibility of use when connected to the maximum electrical service as listed below. If you prefer, a minor circuit board modification will allow the hot tub to accept different electrical service. The operational considerations of these modifications are in the wiring diagram at the end of this manual.

### **Havencrest, Winchester and Windsor Models (50 Hz)**

	<u>230V/20A</u>	<u>230V/30A</u>
Voltage	230 volts	230 volts
Current Draw	15 amps	23 amps
Number of Wires	Three	Three
Circuit Breaker	20 amp dual pole	30 amp dual pole

### **Richmond Model (50 Hz)**

	<u>230V/20A</u>	<u>240V/30A</u>
Voltage	230 volts	240 volts
Current Draw	15 amps	21 amps
Number of Wires	Three	Three
Circuit Breaker	20 amp dual pole	30 amp dual pole

In 30A configuration, the heater will not operate while both jet pumps are operating at high speed.

In 20A configuration, the heater will not operate while either pump is operating in high speed.

## Start Up Instructions

FOR BEST RESULTS, READ EACH STEP IN ITS ENTIRETY BEFORE PROCEEDING WITH THAT STEP.

### 1. PREPARE THE HOT TUB FOR FILLING

- Clear all debris from the hot tub. (Although the hot tub shell has been polished at the factory, you may want to treat it with a specially formulated hot tub cleaner and wax prior to filling the first time.)
- Remove either of the filter.

### 2. FILL THE HOT TUB

- Place the end of your garden hose into the pipe exposed when you removed the filter cartridge.

Important: Always fill your hot tub through the filter pipe after draining. Failure to do so may cause air to be trapped in the pump, preventing the pump from circulating water.

NOTE: Never fill with water from a water softener. If your water is extremely “hard”, it is preferable to fill half-way with hard water and the rest of the way with softened water. Or, you may fill entirely with hard water if you use a special water additive. (Contact Jacuzzi Spa Division for any assistance or questions.)

- Fill the hot tub until the water level is above all jets. Warning: Do not over-fill.
- Remove the hose and replace the filter cartridge.

### 3. TURN ON THE POWER

Turn on the power to the hot tub at the home’s circuit breaker. The heater and the pump’s low speed automatically activate and the LED display on the control panel shows the water temperature.

### 4. ACTIVATE JETS

Press the JETS or JETS 1 button on the control panel once to activate pump 1 in low speed. Press the button a second time to activate pump 1 in high speed and initiate maximum water flow to certain jets.

### 5. ADD START-UP CHEMICALS

Add the hot tub water chemicals (Contact Jacuzzi Spa Division for any assistance or questions). (See the section titled MAINTAINING WATER QUALITY (page 25) for general guidance.)

### 6. SET HOT TUB TO HEAT (Default Set Temp is 100°F (38°C))

To warm the hot tub water up to a comfortable temperature, follow these steps:

- The LED display on the control panel displays the actual temperature of the hot tub water. Press either the COOLER (Down) or WARMER (Up) button to display the “set” temperature for 5 seconds. If you want the water to heat to a different temperature, simply press COOLER or WARMER within 5 seconds while the “set” temperature is displayed. The set temperature advances or decreases by one degree each time one of these sensor pads is pressed.
- The heater will turn off when the temperature corresponding to the thermostat setting is achieved.

**NOTE:**

- The maximum temperature for which the hot tub can be set is 104°F (40°C) and the minimum is 65°F (18°C).
- Setting the thermostat at maximum will not accelerate the heating process. This will only result in a higher ultimate temperature.

**7. PLACE COVER ON HOT TUB**

- Keeping the insulating cover in place anytime the hot tub is not in use will reduce the time required for heating, thereby minimizing operating costs.
- The time required for initial heat-up will vary depending on the starting water temperature and the capacity of your hot tub. Smaller hot tubs heat at a rate of approximately 6 to 8 degrees per hour; larger hot tubs heat at about 4 to 6 degrees per hour.

**DANGER. RISK OF INJURY.** Always check water temperature carefully before entering hot tub.

**Control Panel  
Digital Command Center**

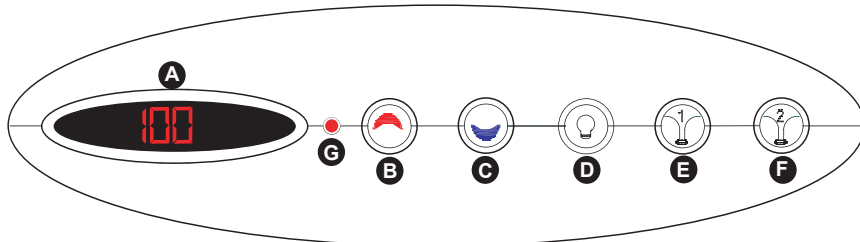

- A. Red LED Display
- B. Warmer Button
- C. Cooler Button
- D. Light Button
- E. Jets 1 Button
- F. Jets 2 Button
- G. Heat Indicator (Off when heater is off, On when heater is on.)

**WARMER AND COOLER BUTTONS**

The hot tub's thermostat is to provide you with optimum control of the hot tub water temperature. This temperature set point can be adjusted from 65°F (18°C) to 104°F (40°C). In conjunction with setting the temperature, these two buttons are used in changing the filter cycles (see "Selecting Filter Cycles", page 19).



## LIGHT

The LIGHT button activates the underwater spa light when pressed. The light will automatically shut off after one hour of operation.

## JETS 1

The JETS 1 button controls the 2-speed pump. Pressing this button switches the pump from off, to low speed, to high speed, and back to off.

## JETS 2

The JETS 2 button controls the high speed pump 2. Pressing this button switches the pump from off, to high speed, and back to off.

NOTE: Auto Shut-off -- Anytime a pump has been manually turned on, it will automatically turn off after approximately 20 minutes. If at this time you desire more jet operation, you may simply turn them back on.

You will notice that occasionally, when you touch the button to turn off the high speed of the pump, the low speed continues to operate. This is normal if the hot tub is in the "Standard" mode and calling for heat, if a filter cycle is in progress or if the heater has recently turned off. (After the heater turns off, the pump continues to circulate water for approximately 30 seconds to cool the heating element.)

## 24-HOUR CIRCULATION PUMP (Havencrest and Windsor only)

Your new Havensrest or Windsor spa includes a 24-hour circulation pump which filters the water continuously while using less energy than a common 100 watt light bulb. *Note: the 24-hour circulation pump system also supplies heated water to the spa when the heater turns on.*

## Initial Start Up

The hot tub control has automatic functions that operate upon start up. Upon power up, the read out will display a three digit number that identifies the software revision. This number will then change to “888” while the system is booting up. Also during the boot up, all of the indicator LED's will be lit.

At the end of the boot up, the water temperature will be displayed. If the temperature is below 100°F (38°C), the low speed pump or circ pump and the heater will turn on until the temperature rises to the preset 100°F (38°C). Approximately two minutes after the system has been initially powered up, the first filtration cycle will begin to operate. Any time after the boot up, you will be able to select a pre-programmed filter cycle and reset your temperature set point.

### Selecting Filter Cycles

(Havencrest and Windsor)

#### FILTRATION

Your new Havensrest or Windsor spa includes a 24-hour circulation pump which filters the water continuously while using less energy than a common 100 watt light bulb. *Note: the 24-hour circulation pump system also supplies heated water to the spa when the heater turns on.*

Proper filtration is an important key to maintaining the clarity of your hot tub's water. The Filtration system is designed for unsurpassed effectiveness at removing debris and suspensions from the water anytime the water is circulating.

You may change the filtration cycle start time by one of the following methods:

1. Turn power to the hot tub off and then back on at the breaker, or
2. Press and hold for three seconds the “WARMER” and “COOLER” buttons at the same time. When the currently set cycle appears (F1-F6) press the jets 1 button one time and the control will go into the initial power up routine.

Example: If you want your first filter cycle start time to be at 4 PM, perform above functions just before the desired start time. Filter cycle start time may vary slightly.

Your hot tub comes with six pre-programmed filtration cycles (F1-F6) and two lockout modes (L1-L2). Of the six filter cycles, three cycles are in the standard mode and three cycles are in the economy mode.

To change the filter cycles, press and hold the “WARMER” button and “COOLER” buttons for 3 seconds. This will get you into the filter cycle programming mode. Use the “WARMER” and “COOLER” buttons to scroll between F1 and L2. This numeric value coincides with a specific filter cycle that is to be used for filtration.

## Filter Cycles

(Havencrest and Windsor)

### STANDARD MODE

#### Selecting the Filtration Mode

Press and hold both control panel WARMER and COOLER buttons at the same time, then release. Then press either the WARMER or COOLER button to select filter mode F0 through L2 below:

#### Standard Filtration Modes

F0 No filter cycles.

F1 1 hour filtration per day (1/2 hour cycle every 12 hours); factory preset.

F2 1-1/2 hour filtration per day (1/2 hour cycle every 8 hours)

F3 2 hour filtration per day (1/2 hour cycle every 6 hours)

#### Economy Filtration Modes

F4 1 hour filtration per day (1/2 hour cycle every 12 hours)

F5 1-1/2 hour filtration per day (1/2 hour cycle every 8 hours)

F6 2 hour filtration per day (1/2 hour cycle every 6 hour)

L1 LOCKOUT - special feature used when cleaning or changing the filter cartridge or any type of non-electrical servicing that requires the hot tub's pump operation to be suspended while the work is completed. The temperature readout flashes in this function.

NOTE: If the hot tub is heating when the system is put into the lock-out mode, the heater will immediately turn off and the pump will cycle water for thirty seconds, then turn off. This will assist in cooling the heater element.

L2 LOCK MODE - Special feature to prevent unauthorized use of your hot tub which disables Jets and Light buttons. Your filter cycles and heating will continue to operate normally. The temperature readout flashes in this function.

## Care and Maintenance of Your Hot Tub

Proper and regular maintenance of your hot tub will help it retain its beauty and performance. Contact Jacuzzi Spa Division for any assistance or questions.

## Filter Cycles

(Richmond and Winchester)

### STANDARD MODE

Heating is automatically controlled by the loss of water temperature. If the hot tub water drops 2°F (1.2°C) below the set temperature, the low speed pump and the heater will automatically turn on. They will both remain on until the water temperature reaches the temperature setpoint.

NOTE: The initial time still operates the filter cycle in this mode to ensure proper filtration.

- F1 2 hours of filtration every 12 hours
- F2 2 hours of filtration every 8 hours
- F3 2 hours of filtration every 6 hours

### ECONOMY MODE

In this mode, the timer determines when the filtering and heating take place.

- F4 2 hours of filtration every 12 hours
- F5 2 hours of filtration every 8 hours
- F6 2 hours of filtration every 6 hours

L1 LOCKOUT - special feature used when cleaning or changing the filter cartridge or any type of non-electrical servicing that requires the hot tub's pump operation to be suspended while the work is completed. The temperature readout flashes in this function.

NOTE: If the hot tub is heating when the system is put into the lockout mode, the heater will immediately turn off and the pump will cycle water for thirty seconds, then turn off. This will assist in cooling the heater element.

L2 LOCK MODE - Special feature to prevent unauthorized use of your hot tub which disables Jets and Light buttons. Your filter cycles and heating will continue to operate normally. The temperature readout flashes in this function.

## Care and Maintenance of Your Hot Tub

Proper and regular maintenance of your hot tub will help it retain its beauty and performance. Contact Jacuzzi Spa Division for any assistance or questions.

## CLEANING THE FILTER

Your hot tub is equipped with cartridge filters located in the skimmer/filter well. Filtering is accomplished when the 2-speed pump 1, on either high or low speed, causes water to flow through the polyester mesh of the filters. As this happens, suspended particles become trapped on the filter's surface.

To ensure optimum performance, it is necessary to remove and clean the filter cartridges, usually once a week, depending on usage and water quality. To accomplish this, follow these steps:

1. Turn off power to the hot tub at the home's breaker panel.
2. Remove the filter lid.
3. Remove the filter cartridges by unthreading from the wall fitting.
4. Using a garden hose with a high-pressure nozzle, rinse debris from the filter pleats beginning at the top and working your way downward. Continue, one section at a time, until you have rinsed all of the filter's pleats.

Periodically, the filter cartridges will need a more thorough cleaning to remove imbedded oils and minerals. For this, we suggest cleaning as above and then soaking the cartridges overnight in a plastic container filled with a solution of water and a specially formulated filter cleanser. Contact Jacuzzi Spa Division for any assistance or questions.

The average life expectancy of a filter cartridge is approximately two years with proper care and water quality maintenance. Contact Jacuzzi Spa Division for any assistance or questions.

## OZONATORS

The Ozone is injected into the water to supplement chemical sanitizers, kill bacteria, oxidize organics and control minerals. Ozone is injected anytime the pump is turned on automatically like in heat call or filter cycles. The ozonator will turn off anytime the pump is manually activated by pressing the jets button. It will remain off until five minutes after that specific function has been turned off.

## DRAINING AND REFILLING

**CAUTION:** There are certain precautions to keep in mind when draining your hot tub. If it is extremely cold, and the hot tub is outdoors, freezing could occur in the lines or the equipment. On the other hand, if it is hot outdoors, do not leave the hot tub's surface exposed to direct sunlight for long periods.

To drain your hot tub, first turn off power to the hot tub. Then, remove the front cabinet panel and locate the drain hose. Pull out the drain hose.

Raise the end of the hose above the water level, remove the cap and connect a garden hose to the male garden hose fitting. Lay the garden hose away from the equipment and turn the knob on the valve to drain the hot tub.

Be sure to close the valve, disconnect the garden hose and replace the cap before refilling. After refilling, turn the power back on.

*After refilling, turn on power to the spa and follow the steps listed under "Start-Up Instructions."*

## CLEANING THE HOT TUB SURFACE

To preserve your hot tub's surface, it is crucial that you avoid using abrasive cleaners or cleansers which have adverse chemical effect on the surface. If you are not certain as to the suitability of a particular cleanser, contact Jacuzzi Spa Division for any assistance or questions.

Regardless of the cleanser used, use care to assure that no soap residue is left on the surface. This could cause severe sudsing when the hot tub is refilled.

Contact Jacuzzi Spa Division for any assistance or questions on specially formulated surface cleaners and sealants which aid in cleaning the hot tub surface and adding a protective coating to enhance the luster of the surface.

## MAINTAINING THE SYNTHETIC CABINET

Your new spa's synthetic cabinet requires little or no maintenance of any kind. To clean, simply wipe the cabinet with a clean towel and a mild soap solution.

<p><b>NOTE:</b> Never spray cabinet with a garden hose for any reason since this action may induce an electrical short in the spa's electrical equipment.</p>
---

## MAINTAINING THE COVER

Using the insulating hot tub cover anytime the hot tub is not in use will significantly reduce your operating costs, heatup time and maintenance requirements.

To prolong the life of the cover, handle it with care and clean it regularly using mild soap and water. Periodic treatments with a quality vinyl conditioner will help protect against deterioration caused by UV rays from the sun. Never allow anyone to stand or sit on the cover, and avoid dragging it across rough surfaces.

## WINTERIZING

Your hot tub is designed to automatically protect itself against freeze damage when operating properly. Refer to "ICE - Freeze Condition" details on page 27. During periods of severe freezing temperatures, you should periodically check to be certain the hot tub's electrical supply has not been interrupted. In extreme, bitter cold weather with ambient temperatures of -20°F (-29°C) or colder, the hot tub must be drained and purged to prevent freeze damage.

For expert winterization of your hot tub, contact Jacuzzi Spa Division. In emergency situations, damage can be minimized by taking the following steps:

1. Remove power to hot tub.
2. Pull out the drain cap attached to the drain hose located behind the synthetic cabinet panel. Raise drain hose above water line, then attach garden hose. Lay drain hose and garden hose flat on ground away from the equipment and turn the knob on the valve to drain hot tub.
3. As the water level drops below the seats, use whatever means available to get it out of the recessed seating areas and into the footwell.
4. When the water level ceases to drop, use whatever means available to remove any remaining water from the footwell (wet and dry vacuum recommended).
5. Access the equipment compartment by removing the cabinet panel from the control panel side on all models. Locate the pump drain plug(s) on the front of each pump. Remove these plugs to allow the water to drain from the pump(s) and heater. (Note: up to two gallons of water may be released during this procedure. Use a wet/dry vacuum or other means to prevent the equipment bay from flooding). Replace pump(s) drain plugs.
6. Loosen the heater union on one side of the heater and gently separate the heater flange from their mating pipe, allowing it to drain. Approximately 1/2 gallon of water will drain. Use a wet/dry vacuum or other means to keep water from flooding the equipment compartment. Reinstall both union nuts after system has drained.
7. Disconnect the garden hose, close the valve and replace the drain cap. Reinstall the synthetic cabinet panel and cover the hot tub so that no casual moisture can enter the hot tub.

Consult Jacuzzi Spa Division if you have any questions regarding winter use or winterizing.

## Restarting Your Hot Tub In Cold Weather

If you want to start up your hot tub after it has sat empty for a time in freezing temperatures, be aware that the water remaining in certain sections of the piping may still be frozen. This situation will block water flow preventing the hot tub from operating properly and possibly damaging the equipment. We recommend you consult your local pool and spa supply for guidance before attempting to re-start your hot tub under these conditions.

## Maintaining Water Quality

Maintaining the quality of the water within specified limits will serve to enhance your enjoyment and prolong the life of your hot tub's equipment. It is a fairly simple task, but it requires regular attention because the water chemistry involved is a balance of several factors. A careless attitude in regard to water maintenance will result in poor conditions for soaking and even damage to your hot tub investment.

For specific guidance on maintaining water quality, contact Jacuzzi Spa Division, who can recommend appropriate chemical products for sanitizing and balancing your hot tub water.

**Caution:** Never store hot tub chemicals inside the hot tub's equipment bay.

### pH Control

pH is a measure of the relative acidity or alkalinity of water and is measured on a scale of 0 to 14. The midpoint of 7 is said to be neutral, above which is alkaline and below which is acidic.

In hot tub water, *it is very important to maintain a slightly alkaline condition of 7.2 to 7.8.* Problems become proportionately more severe when this range is exceeded or diminished. A low pH will be corrosive to metals in the hot tub equipment. A high pH will cause minerals to deposit (scaling) on the interior of the hot tub and equipment. In addition, the ability of the sanitizing agents to keep the water clean is diminished as the pH moves further outside the ideal range.

### SANITIZING

To destroy bacteria and organic compounds in the hot tub water, a sanitizer must be used regularly. A residual sanitizer level of 1 to 3 ppm (parts per million) is generally considered desirable.

Bromine tablets, a two-part bromine system or granular chlorine (dichlor) are all acceptable sanitizers.



**IMPORTANT:** Do not use chlorine tablets (trichlor) in your hot tub. This chemical can have an extremely corrosive effect on certain materials in the hot tub. Damage caused by use of this chemical, or improper use of any chemical is not covered under the hot tub's warranty.

## OTHER ADDITIVES

Many other additives are available for your hot tub. Some are necessary to compensate for out-of-balance water, some aid in cosmetic water treatment and others simply alter the feel or smell of the water. Jacuzzi Spa Division can advise you on the use of these additives.

## WATER SANITIZATION WITH OZONE

The Ozone Water Purification System, factory installed on your hot tub, is designed to work in conjunction with chemical sanitizers to keep your hot tub water cleaner, clearer, and fresher, allowing for longer intervals between drainings.

The Ozone system works by converting oxygen to ozone as air passes through an enclosed chamber located in the equipment compartment of your hot tub. When this powerful oxidizer is mixed with the hot tub water, bacteria and contaminants are destroyed and organic compounds are reduced to their lowest elements for removal by the filtration system.

Although your Ozone system will substantially reduce the need for chemical sanitizers, it is recommended that either bromine or granular chlorine be used to provide residual germ-killing action when the ozone system is not in operation. In addition, it is important that the chemical balance be maintained within the proper parameters for the ozone to provide effectiveness. For more detailed information about proper use of chemicals contact Jacuzzi Spa Division.

## Troubleshooting

Your hot tub has a self-diagnostic control system. The system will automatically display the following if a problem is detected.

**SN1 Nonfunctional hi-limit sensor**

Open or a short in hi-limit sensor. Heater is deactivated. This must be repaired by a qualified service technician.

**SN2 Nonfunctional temperature sensor**

Open or short in temperature sensor. Heater is deactivated. This must be repaired by a qualified service technician.

**FL1 Water flow problem**

Pressure switch is not closed when the pump is activated. Heater is deactivated. Proper flow of water is inhibited or pressure switch has malfunctioned. Check for proper water level, pump is primed and/or clogged filter. Contact Jacuzzi Spa Division.

**FL2 Pressure switch problem**

Pressure switch is closed, while pump is deactivated. Contact Jacuzzi Spa Division.

**COL Cool condition**

If the water temperature drops 20°F (11°C) below the set temperature (in economy mode), the low speed pump and the heater will activate to bring the temperature within 15°F (8°C) of the set temperature. No corrective action is required.

**ICE Freeze condition**

A potential freeze condition of 55°F (13°C) has been detected. No action is required. The low speed pump will be activated along with the heater. The hot tub will automatically bring the water temperature up, until the hot tub is out of danger (see "Winterizing", page 24).

**OH High temperature condition**

Water temperature is above acceptable limits. Do not enter the hot tub water. Water temperature has reached 112°F (44°C) and the low speed of the pump is activated to circulate the water through the heater.

**- - - Watchdog**

Water temperature has reached 120°F (49°C). The entire system is disabled. Contact Jacuzzi Spa Division.

## Troubleshooting Procedures

In the unlikely event your hot tub is not working the way you believe it should, please first review all the installation and operating instructions in this manual and check the message on the panel display; second, if you are still not satisfied it is working properly, please follow the appropriate troubleshooting instructions.

### **PROBLEM**

NONE OF THE COMPONENTS OPERATE (i.e. pump, light)

### **PROCEDURE**

Check the control panel lights.

1. If there are letters or symbols displayed on the screen, refer to the previous section to determine meaning and action required.
2. If nothing appears on the screen:
  - a. Check the household circuit breaker.
  - b. Contact Jacuzzi Spa Division

PUMP DOES NOT OPERATE BUT LIGHT DOES OPERATE.

Depress "Jets" sensor.

1. If no sound is detected or if a "buzzing" sound is detected, turn off power to hot tub and contact Jacuzzi Spa Division.
2. If motor operates but no water flows to jets:
  - a. Pump may not be properly primed. See instructions below.
  - b. Contact Jacuzzi Spa Division.

### **Pump Priming Instructions: Turn Hot Tub Off!**

Remove filter and insert end of garden hose into filter pipe. Seal-off pipe opening around hose using a large, clean rag and turn on maximum water flow through the hose. After about 30 seconds, turn off water, remove hose and rag, reinstall filter and activate pump's high speed.

**IMPORTANT:** If freezing conditions exist and pump is not operational, take measures to protect the system from freeze damage. See "Winterizing", page 24.

POOR JET ACTION

1. Make certain the pump is on high speed.
2. Make sure jets are fully open.
3. Open air control for the jet system selected.
4. Check for adequate water level.
5. Check for dirty filter.

WATER IS TOO HOT

1. Reduce thermostat setting.
2. Reduce filtration cycle length. (Even without heater on, water temperature can increase from prolonged pump operation.)

NO HEAT

1. Check thermostat setting.
2. Keep the cover in place while heating.
3. If “heater on” indicator is lit. but no temperature rise is experienced after a reasonable period of time, contact your dealer or authorized service center.

Your authorized local service center is a trained service repair center. Should checking the above steps fail to correct the problem, please call Jacuzzi Spa Division so that they may arrange service.

Your local service center’s phone number: \_\_\_\_\_

Blue Ridge spas builds the best hot tubs in the industry. Nonetheless, we are always striving to improve the quality and features of our products. Your input as hot tub owner is a cherished part of this process. If you have any comments or suggestions, or if you wish to be informed on any new products for your hot tub, please write to us.

CONGRATULATIONS on your good taste and welcome to the happiest and most relaxed family in the world!

# Electrical Wiring Diagram Havencrest and Windsor (50 Hz)

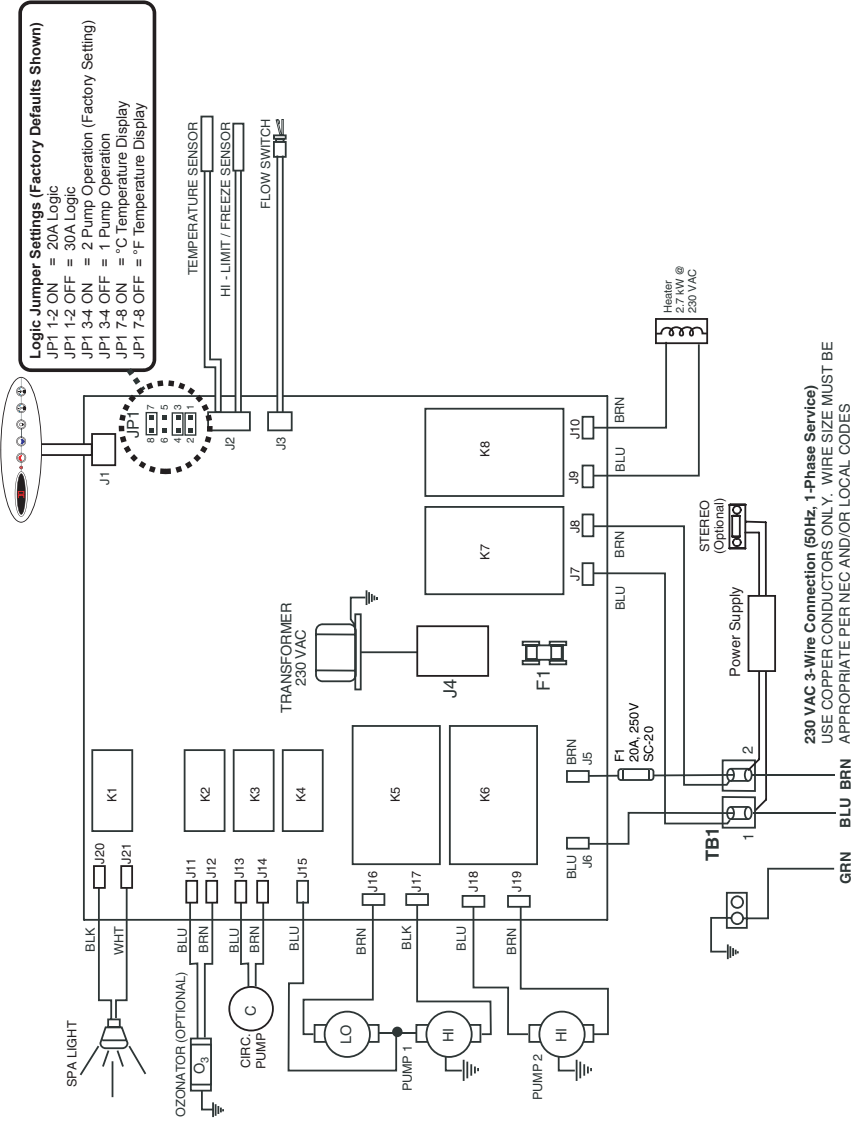

# Electrical Wiring Diagram Winchester (50 Hz)

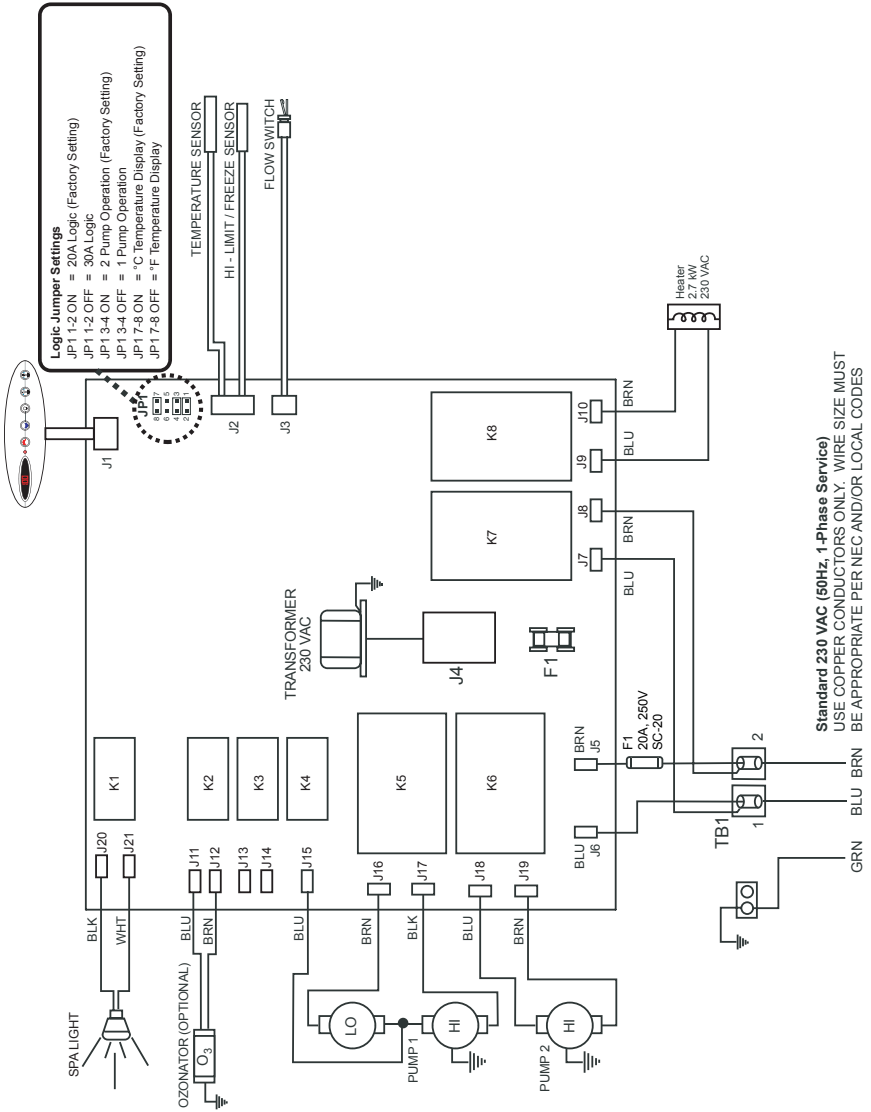

**Standard 230 VAC (50Hz, 1-Phase Service)**  
 USE COPPER CONDUCTORS ONLY. WIRE SIZE MUST  
 BE APPROPRIATE PER NEC AND/OR LOCAL CODES

# Electrical Wiring Diagram Richmond (50 Hz)

**Logic Jumper Settings**

JP1 1-2 ON = 20A Logic (Factory Setting)

JP1 1-2 OFF = 30A Logic

JP1 7-8 ON = °C Temperature Display (Factory Setting)

JP1 7-8 OFF = °F Temperature Display

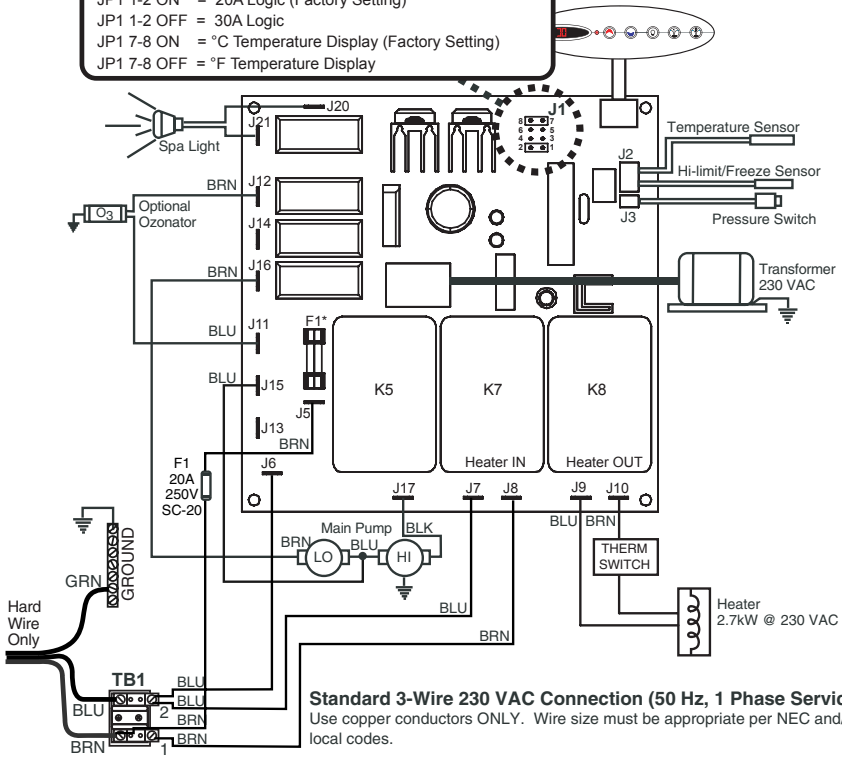

**Standard 3-Wire 230 VAC Connection (50 Hz, 1 Phase Service)**  
 Use copper conductors ONLY. Wire size must be appropriate per NEC and/or local codes.

Notes:



Notes:

Notes:

14525 Monte Vista Ave, Chino, CA 91710/USA

REV. 11/10/04