



Hot Tubs

2005 Dimension And Specification Handbook

The spa illustrations below function as a virtual table of contents. Simply click on the spa of choice to immediately jump to that page. The table of contents in the following pages is also electronically linked for ease-of-use.

Jacuzzi 300 Series Hot Tubs



J-385



J-375



J-365



J-355



J-345



J-335



J-325



J-315

Jacuzzi J-200 Series Hot Tubs



J-230



J-220



J-210

Important Safety Instructions - All Models



© 2005 Jacuzzi Hot Tubs. Jacuzzi may make product modifications and enhancements. Therefore, specifications may change without notice. Dimensions are approximate and for reference only.



CAUTION: Always measure each spa for exact dimensions before designing its foundational support and/or decking.



When designing a foundational support, always account for the following load factors:

1. Filled spa weight, plus (+)
2. Combined occupant weight at the maximum seating capacity, plus (+)
3. Weight of the support decking, when applicable.



The technical data given in this publication is for reference only. It implies no warranty of any kind.



Table of Contents

Jacuzzi J-300 Series Hot Tubs

J-385 Specifications 4
J-385 Operation..... 5

J-375 Specifications 6
J-375 Operation..... 7

J-365 Specifications 8
J-365 Operation..... 9

J-355 Specifications 10
J-355 Operation..... 11

J-345 Specifications 12
J-345 Operation..... 13

J-335 Specifications 14
J-335 Operation..... 15

J-325 Specifications 16
J-325 Operation..... 17

J-315 Specifications 18
J-315 Operation..... 19

Jacuzzi J-200 Series Hot Tubs

J-230 Specifications 20
J-230 Operation..... 21

J-220 Specifications 22
J-220 Operation..... 23

J-210 Specifications 24
J-210 Operation..... 25

Detailed Dimensions - All 300 Series Hot Tubs..... 26
Detailed Dimensions - All 200 Series Hot Tubs 27

Jacuzzi J-385

Dimensions	94" x 94" x 38" (239cm x 239cm x 97cm); For Detailed Dimensions, See Page 26	
Dry Weight	1,042 lbs (473 kg)	
Filled Weight	5,607 lbs (2,581 kg)	
Water Capacity (Avg. Fill)	550 US gallons (2,082 Liters)	
Electronic Controls	Solid State, LCD User Interface Displays Temperature, Time, Cycles and Fingertip Jet Control. Offers Customizing of Preprogrammed Filtration Cycles and Water Temperature Setting. Also Includes 1 Remote Control Panel for Secondary Jet Control.	
Pump 1 (North America)	2-Speed, 4.2 hp break, 2.5 hp continuous	
(Export)	2-Speed, 2.0 hp continuous	
Pump 2 (North America)	1-Speed, 4.2 hp break, 2.5 hp continuous	
(Export)	1-Speed, 2.0 hp continuous	
Pump 3 (North America)	1-Speed, 3.2 hp break, 2.0 hp continuous	
(Export)	1-Speed, 2.0 hp continuous	
Circulation Pump	Programmable for Daily Start Time and Duration	
Total PowerPro Jets	43	
Maxx PowerPro (MX)	7	
PowerPro (LX)	7	
Mini PowerPro (FX)	27	
Micro PowerPro (SX)	2	
Jet Selectors	2	
Air Controls	Five, On / Off Pushbutton Type	
Total Foot Jet Therapy	3	
Water Management System	Two 60 ft ² Filter Cartridges; Filter 1 on 24-Hour Circulation Pump; Filter 2 on 2-Speed Pump 1; Ready for optional CD Ozone Generator (Factory Installed Ozone Injector And Ozone Dispersion Chamber)	
Lighting	One Underwater LED ProLite with 7 Color Modes + Colored Waterfalls	
Cabinet	Synthetic Cabinet in Harvest Wheat, Autumn Red or Silverwood Color	
Acrylic Colors	Textured Bluegrass, Marine, Onyx, Sahara, or Sand; Marbled Platinum, or Solid Azure or Silver	
Headrests	5	
Waterfalls	Two with Independent Flow Rate / On-Off Adjustment; Powered by Pump 1	
Electrical Requirements	North American 60 Hz Models: 240 VAC @ 40A, 50A, or 60A Export 50 Hz Models: 230-240 VAC @ 35A or 40A, or suitably rated circuit breaker to comply with local electrical codes. Certain countries may require dual power inputs; two breakers are required for this configuration.	
Warranty	North American 60 Hz Models: 10 Years Shell, 7 Years Shell Surface, 5 Years for Plumbing Component Leaks, 5 Years Equipment & Controls; Export 50 Hz Models: 2 Years Plumbing Component Leaks, 2 Years Equipment & Controls	
Seating Capacity	6 - 7	
Audio System (Optional)	AM/FM/CD Stereo Receiver with Dual Pop-Up Speakers And Remote	

Dimensions/Specifications are Subject to Change Without Notice

Jacuzzi J-385

Jet Selector / Air Control Diagram

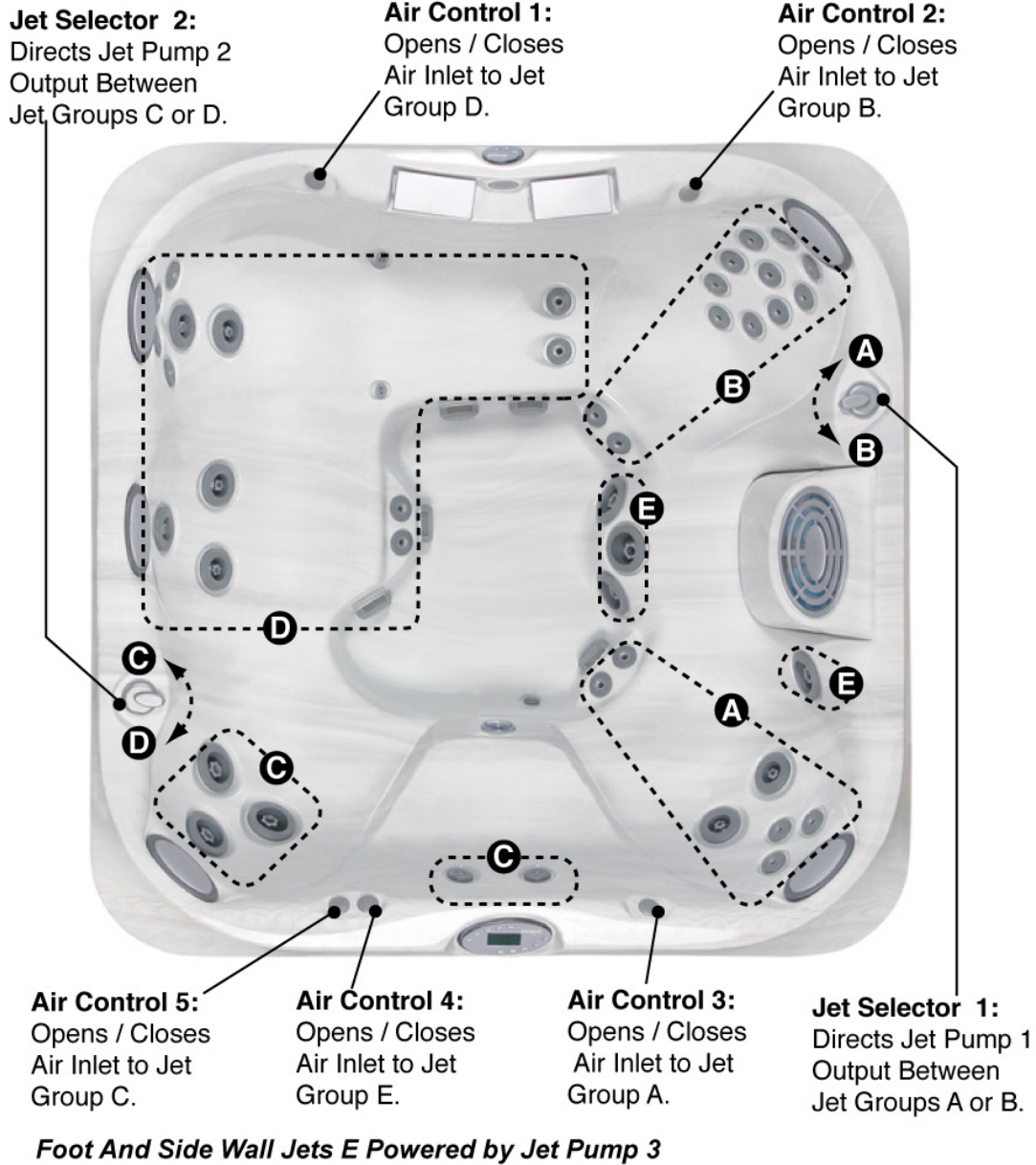

Seat Depths

A = 27.00" (68.6cm)
B = 23.00" (58.4cm)
C = 28.50" (72.4cm)
D = 22.75" (57.8cm)
E = 26.50" (67.3cm)

F = 17.50" (44.5cm)
G = 27.50" (69.9cm)
H = 27.00" (68.6cm)
I = 33.50" (85.1cm)

Listed Dimensions
Represent Distance from
Top of Acrylic to Lowest
Point in Seat.



Dimensions/Specifications Subject to Change Without Notice

Jacuzzi J-375

Dimensions	91" x 91" x 38" (231cm x 231cm x 97cm); For Detailed Dimensions, See Page 26	
Dry Weight	960 lbs (436 kg)	
Filled Weight	4,936 lbs (2,239 kg)	
Water Capacity (Avg. Fill)	480 US gallons (1,817 Liters)	
Electronic Controls	Solid State, LCD User Interface Displays Temperature, Time, Cycles and Fingertip Jet Control. Offers Customizing of Preprogrammed Filtration Cycles and Water Temperature Setting. Also Includes 1 Remote Control Panel for Secondary Jet Control.	
Pump 1 (North America)	2-Speed, 4.2 hp brake, 2.5 hp continuous	
(Export)	2-Speed, 2.0 hp continuous	
Pump 2 (North America)	1-Speed, 4.2 hp brake, 2.5 hp continuous	
(Export)	1-Speed, 2.0 hp continuous	
Circulation Pump	Yes, Programmable for Daily Start Time and Duration	
Total PowerPro Jets	34	
Maxx PowerPro (MX)	4	
PowerPro (LX)	5	
Mini PowerPro (FX)	23	
Micro PowerPro (SX)	2	
Jet Selectors	2	
Air Controls	Five, On / Off Pushbutton Type	
Total Foot Jet Therapy	5	
Water Management System	Two 60 ft ² Filter Cartridges; Filter 1 on 24-Hour Circulation Pump; Filter 2 on 2-Speed Pump 1; Ready for optional CD Ozone Generator (Factory Installed Ozone Injector And Ozone Dispersion Chamber)	
Lighting	One Underwater LED ProLite with 7 Color Modes + Colored Waterfalls	
Cabinet	Synthetic Cabinet in Harvest Wheat, Autumn Red or Silverwood Color	
Acrylic Colors	Textured Bluegrass, Marine, Onyx, Sahara, or Sand; Marbled Platinum, or Solid Azure or Silver	
Headrests	4	
Waterfalls	Two with Independent Flow Rate / On-Off Adjustment; Powered by Pump 1	
Electrical Requirements	North American 60 Hz Models: 240 VAC @ 35A, 50A, or 60A Export 50 Hz Models: 230-240 VAC @ 20A, 30A or 40A, or suitably rated circuit breaker to comply with local electrical codes. Certain countries may require dual power inputs; two breakers are required for this configuration.	
Warranty	North American 60 Hz Models: 10 Years Shell, 7 Years Shell Surface, 5 Years for Plumbing Component Leaks, 5 Years Equipment & Controls; Export 50 Hz Models: 2 Years Plumbing Component Leaks, 2 Years Equipment & Controls	
Seating Capacity	6 - 7	
Audio System (Optional)	AM/FM/CD Stereo Receiver with Dual Pop-Up Speakers And Remote	



Jacuzzi J-375

Jet Selector / Air Control Diagram

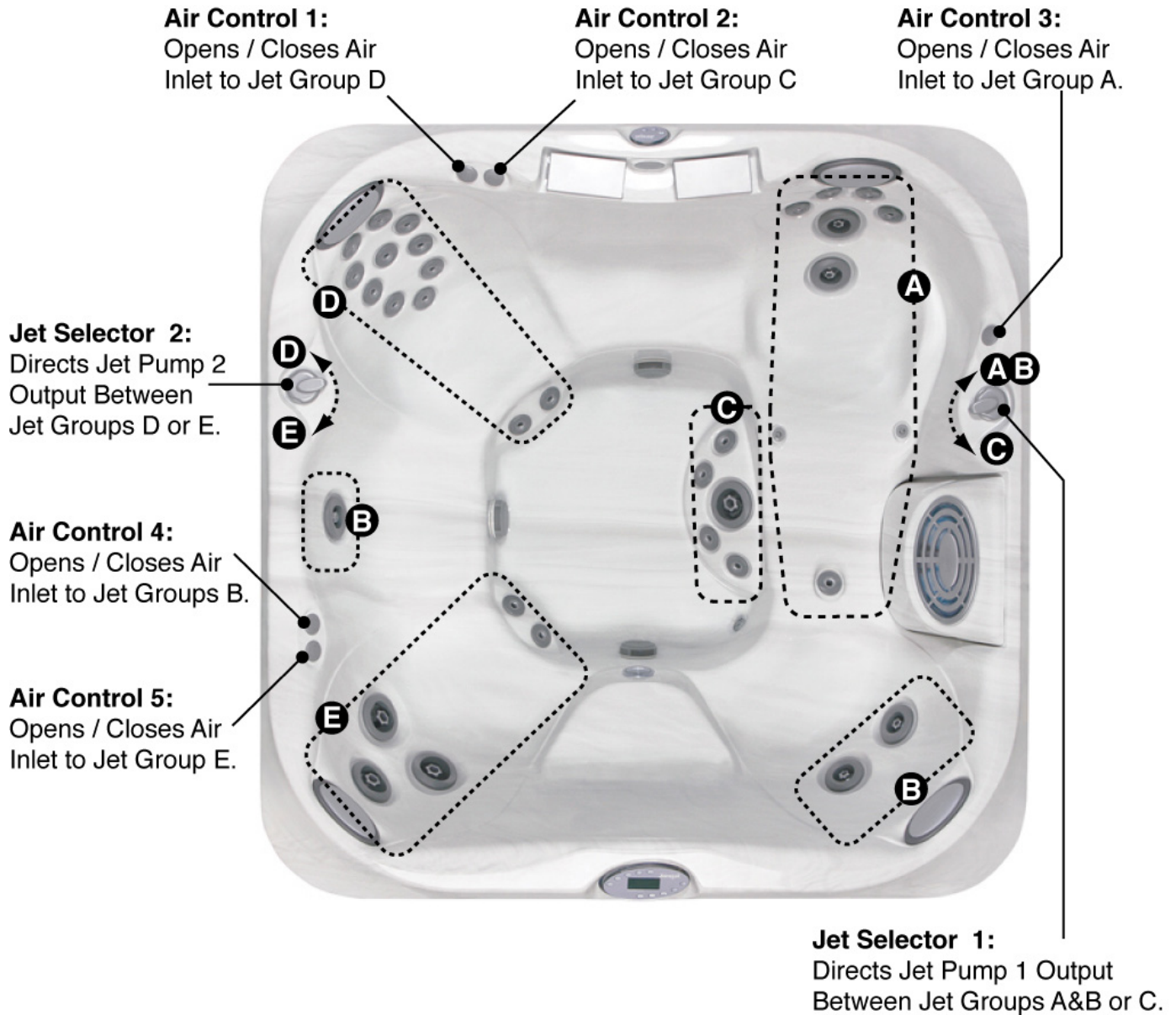

Seat Depths

A = 28.75" (73.0cm)
 B = 21.50" (54.6cm)
 C = 26.75" (67.9cm)
 D = 22.50" (57.2cm)
 E = 26.00" (66.0cm)

F = 19.00" (48.3cm)
 G = 27.00" (68.6cm)
 H = 26.50" (67.3cm)
 I = 34.00" (86.4cm)

Listed Dimensions Represent Distance from Top of Acrylic to Lowest Point in Seat.



Dimensions/Specifications Subject to Change Without Notice

Jacuzzi J-365

Dimensions	91" x 84" x 38" (231cm x 213cm x 97cm); For Detailed Dimensions, See Page 26	
Dry Weight	887 lbs (402 kg)	
Filled Weight	3,991 lbs (1,810kg)	
Water Capacity (Avg. Fill)	374 US gallons (1,416 Liters)	
Electronic Controls	Solid State, LCD User Interface Displays Temperature, Time, Cycles and Fingertip Jet Control. Offers Customizing of Preprogrammed Filtration Cycles and Water Temperature Setting.	
Pump 1 (North American)	2-Speed, 4.2 hp brake, 2.5 hp continuous	
(Export)	2-Speed, 2.0 hp continuous	
Pump 2 (North American)	1-Speed, 4.2 hp brake, 2.5 hp continuous	
(Export)	1-Speed, 2.0 hp continuous	
Circulation Pump	Yes, Programmable for Daily Start Time and Duration	
Total PowerPro Jets	30	
Maxx PowerPro (MX)	3	
PowerPro (LX)	5	
Mini PowerPro (FX)	22	
Micro PowerPro (SX)	N/A	
Jet Selectors	2	
Air Controls	Five, On / Off Pushbutton Type	
Total Foot Jet Therapy	4	
Water Management System	Two 60 ft ² Filter Cartridges; Filter 1 on 24-Hour Circulation Pump; Filter 2 on 2-Speed Pump 1; Ready for optional CD Ozone Generator (Factory Installed Ozone Injector And Ozone Dispersion Chamber)	
Lighting	One Underwater LED ProLite with 7 Color Modes + Colored Waterfall	
Cabinet	Synthetic Cabinet in Harvest Wheat, Autumn Red or Silverwood Color	
Acrylic Colors	Textured Bluegrass, Marine, Onyx, Sahara, or Sand; Marbled Platinum, or Solid Azure or Silver	
Headrests	4	
Waterfall	One with Independent Flow Rate / On-Off Adjustment; Powered by Pump 1	
Electrical Requirements	North American 60 Hz Models: 240 VAC @ 35A, 50A, or 60A Export 50 Hz Models: 230-240 VAC @ 20A, 30A or 40A, or suitably rated circuit breaker to comply with local electrical codes. Certain countries may require dual power inputs; two breakers are required for this configuration.	
Warranty	North American 60 Hz Models: 10 Years Shell, 7 Years Shell Surface, 5 Years for Plumbing Component Leaks, 5 Years Equipment & Controls; Export 50 Hz Models: 2 Years Plumbing Component Leaks, 2 Years Equipment & Controls	
Seating Capacity	6	
Audio System (Optional)	AM/FM/CD Stereo Receiver with Dual Pop-Up Speakers And Remote	

Dimensions/Specifications are Subject to Change Without Notice



Jacuzzi J-365

Jet Selector / Air Control Diagram

Air Control 1:
Opens / Closes
Air Inlet to Jet
Group B

Air Control 2:
Opens / Closes
Air Inlet to Foot
Jet Group D

Air Control 3:
Opens / Closes
Air Inlet to Jet
Group A



Jet Selector 2:
Directs Jet Pump 2
Output Between Jet
Groups C or E.

Air Control 4:
Opens / Closes
Air Inlet to All
Seat Jets C

Air Control 5:
Opens / Closes
Air Inlet to All
Seat Jets E

Jet Selector 1:
Directs Jet Pump 1
Output Between Jet
Groups A or B.

Note: Footwell Jets D are always on when Pump 2 is activated.

Seat Depths

A = 25.00" (63.5cm)
B = 23.25" (59.1cm)
C = 28.00" (71.1cm)
D = 22.50" (57.2cm)
E = 27.00" (68.6cm)

F = 19.25" (48.9cm)
G = 26.50" (67.3cm)
H = 25.25" (64.1cm)
I = 33.50" (85.1cm)

Listed Dimensions
Represent Distance from
Top of Acrylic to Lowest
Point in Seat.



Dimensions/Specifications Subject to Change Without Notice

Jacuzzi J-355

Dimensions	91" x 84" x 38" (231cm x 213cm x 97cm); For Detailed Dimensions, See Page 26	
Dry Weight	882 lbs (400 kg)	
Filled Weight	3,895 lbs (1,767 kg)	
Water Capacity (Avg. Fill)	363 US gallons (1,374 Liters)	
Electronic Controls	Solid State, LCD User Interface Displays Temperature, Time, Cycles and Fingertip Jet Control. Offers Customizing of Preprogrammed Filtration Cycles and Water Temperature Setting.	
Pump 1 (North American)	2-Speed, 4.2 hp brake, 2.5 hp continuous (Export)..... 2-Speed, 2.0 hp continuous	
Pump 2 (North American)	1-Speed, 4.2 hp brake, 2.5 hp continuous (Export)..... 1-Speed, 2.0 hp continuous	
Circulation Pump	Yes, Programmable for Daily Start Time and Duration	
Total PowerPro Jets	27	
Maxx PowerPro (MX)	5	
PowerPro (LX)	3	
Mini PowerPro (FX)	19	
Micro PowerPro (SX)	N/A	
Jet Selectors	2	
Air Controls	Four, On / Off Pushbutton Type	
Total Foot Jet Therapy	2	
Water Management System	Two 60 ft ² Filter Cartridges; Filter 1 on 24-Hour Circulation Pump; Filter 2 on 2-Speed Pump 1; Ready for optional CD Ozone Generator (Factory Installed Ozone Injector And Ozone Dispersion Chamber)	
Lighting	One Underwater LED ProLite with 7 Color Modes + Colored Waterfall	
Cabinet	Synthetic Cabinet in Harvest Wheat, Autumn Red or Silverwood Color	
Acrylic Colors	Textured Bluegrass, Marine, Onyx, Sahara, or Sand; Marbled Platinum, or Solid Azure or Silver	
Headrests	3	
Waterfall	One with Independent Flow Rate / On-Off Adjustment; Powered by Pump 1	
Electrical Requirements	North American 60 Hz Models: 240 VAC @ 35A, 50A, or 60A Export 50 Hz Models: 230-240 VAC @ 20A, 30A or 40A, or suitably rated circuit breaker to comply with local electrical codes. Certain countries may require dual power inputs; two breakers are required for this configuration.	
Warranty	North American 60 Hz Models: 10 Years Shell, 7 Years Shell Surface, 5 Years for Plumbing Component Leaks, 5 Years Equipment & Controls; Export 50 Hz Models: 2 Years Plumbing Component Leaks, 2 Years Equipment & Controls	
Seating Capacity	5 - 6	
Audio System (Optional)	AM/FM/CD Stereo Receiver with Dual Pop-Up Speakers And Remote	

Dimensions/Specifications are Subject to Change Without Notice



Jacuzzi J-355

Jet Selector / Air Control Diagram

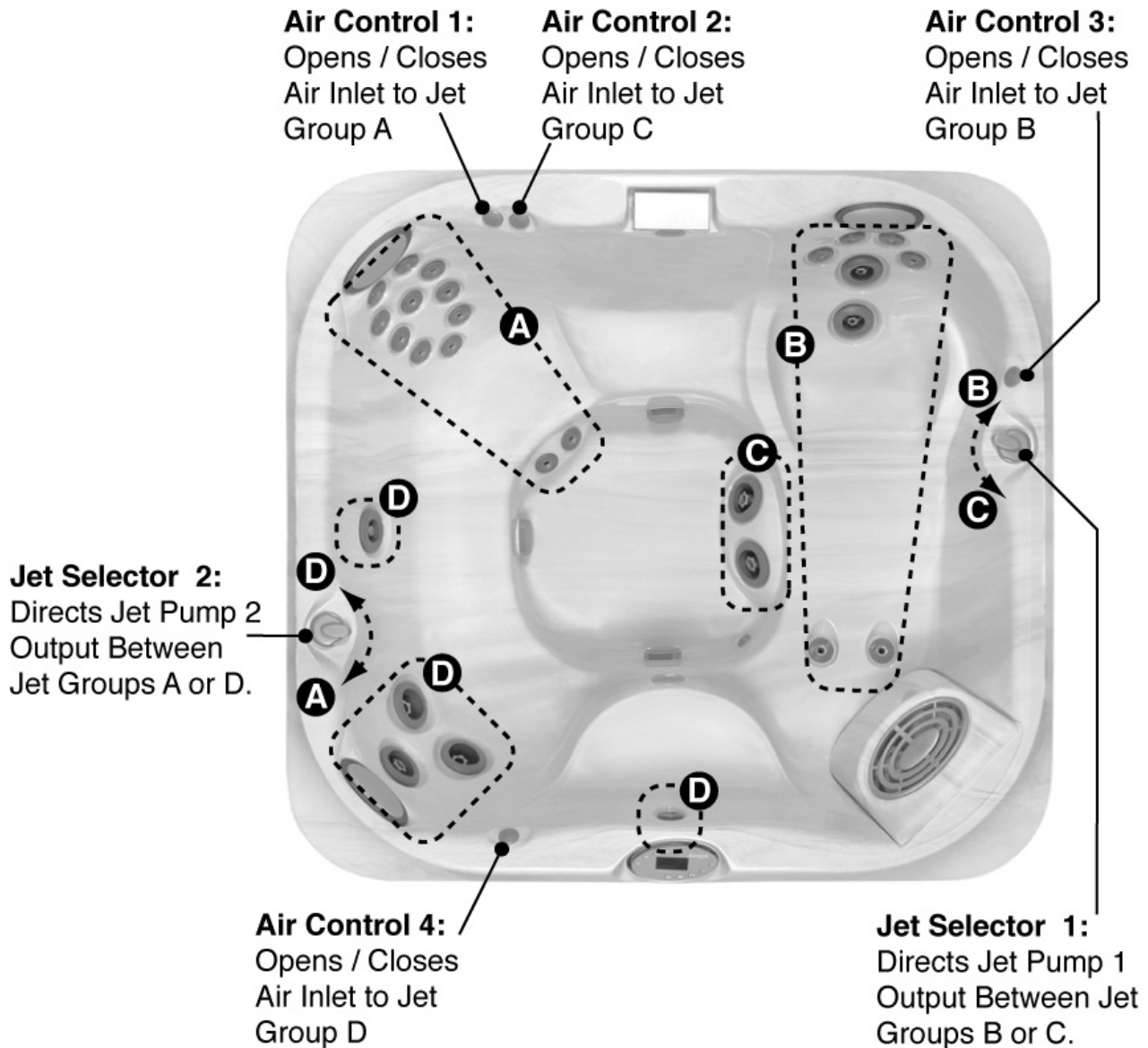

Seat Depths

A = 29.00" (73.6cm)
B = 21.75" (55.2cm)
C = 27.00" (68.6cm)
D = 22.75" (57.8cm)
E = 13.75" (34.9cm)

F = 27.50" (69.9cm)
G = 26.50" (67.3cm)
H = 33.25" (84.5cm)

Listed Dimensions
Represent Distance from
Top of Acrylic to Lowest
Point in Seat.



Dimensions/Specifications Subject to Change Without Notice

Jacuzzi J-345

Dimensions	84" x 84" x 36" (213cm x 213cm x 92cm); For Detailed Dimensions, See Page 26	
Dry Weight	882 lbs (400 kg)	
Filled Weight	3,611 lbs (1,638 kg)	
Water Capacity (Avg. Fill)	336 US gallons (1,272 Liters)	
Electronic Controls	Solid State Electronic Controls with LED Readout, Programmable Temperature, Filtration, and Heat Cycles	
Pump 1 (North American)	2-Speed, 4.2 hp brake, 2.5 hp continuous	
(Export)	2-Speed, 2.0 hp continuous	
Pump 2 (North American)	1-Speed, 4.2 hp brake, 2.5 hp continuous	
(Export)	1-Speed, 2.0 hp continuous	
Circulation Pump	Yes	
Total PowerPro Jets	25	
Maxx PowerPro (MX)	5	
PowerPro (LX)	4	
Mini PowerPro (FX)	16	
Micro PowerPro (SX)	N/A	
Jet Selectors	2	
Air Controls	Four, On / Off Pushbutton Type	
Total Foot Jet Therapy	2	
Water Management System	Two 60 ft ² Filter Cartridges; Filter 1 on 24-Hour Circulation Pump; Filter 2 on 2-Speed Pump 1; Ready for optional CD Ozone Generator (Factory Installed Ozone Injector And Ozone Dispersion Chamber)	
Lighting	One Underwater LED ProLite with 7 Color Modes + Colored Waterfall	
Cabinet	Synthetic Cabinet in Harvest Wheat, Autumn Red or Silverwood Color	
Acrylic Colors	Textured Bluegrass, Marine, Onyx, Sahara, or Sand; Marbled Platinum, or Solid Azure or Silver	
Headrests	4	
Waterfall	Includes Flow Rate / On-Off Adjustment; Powered by Pump 1	
Electrical Requirements	North American 60 Hz Models: 240 VAC @ 35A, 50A, or 60A Export 50 Hz Models: 230-240 VAC @ 20A, 30A or 40A, or suitably rated circuit breaker to comply with local electrical codes. Certain countries may require dual power inputs; two breakers are required for this configuration.	
Warranty	North American 60 Hz Models: 10 Years Shell, 7 Years Shell Surface, 5 Years for Plumbing Component Leaks, 5 Years Equipment & Controls; Export 50 Hz Models: 2 Years Plumbing Component Leaks, 2 Years Equipment & Controls	
Seating Capacity	4 - 5	
Audio System (Optional)	AM/FM/CD Stereo Receiver with Dual Pop-Up Speakers And Remote	

Dimensions/Specifications are Subject to Change Without Notice



Jacuzzi J-345

Jet Selector / Air Control Diagram

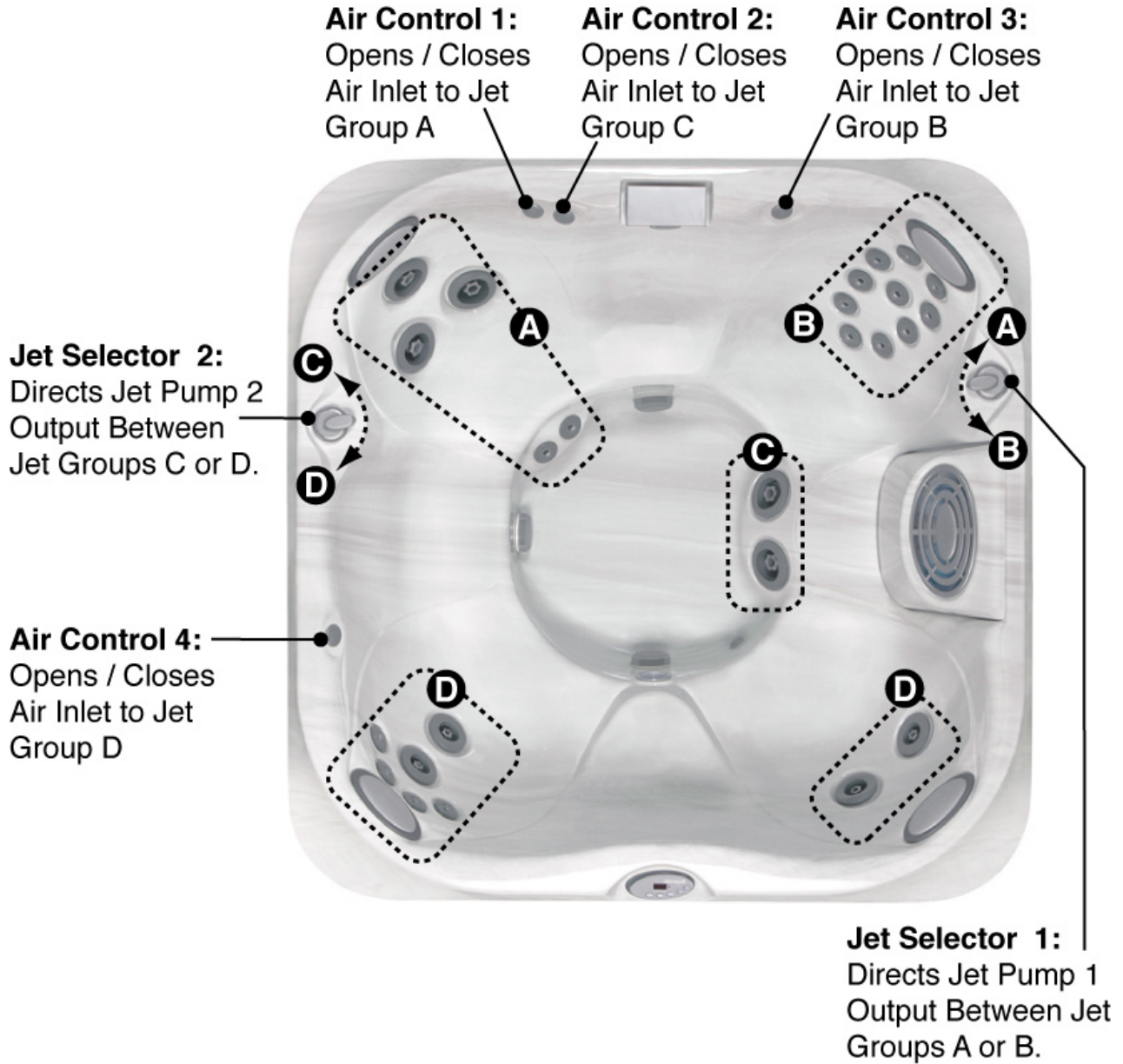

Seat Depths

A = 25.50" (64.8cm)
B = 24.00" (60.1cm)
C = 28.50" (72.4cm)
D = 23.00" (58.4cm)
E = 27.50" (69.9cm)

F = 19.75" (50.2cm)
G = 27.00" (58.6cm)
H = 25.75" (65.4cm)
I = 34.00" (86.4cm)

Listed Dimensions
Represent Distance from
Top of Acrylic to Lowest
Point in Seat.



Jacuzzi J-335

Dimensions	84" x 84" x 36" (213cm x 213cm x 91cm); For Detailed Dimensions, See Page 26
Dry Weight	781 lbs (354 kg)
Filled Weight	3,752 lbs (1,702 kg)
Water Capacity (Avg. Fill)	358 US gallons (1,355 Liters)
Electronic Controls	Solid State Electronic Controls with LED Readout, Programmable Temperature, Filtration, and Heat Cycles
Pump 1 (North American)	2-Speed, 4.2 hp brake, 2.5 hp continuous
(Export)	2-Speed, 2.0 hp continuous
Pump 2 (North American)	1-Speed, 4.2 hp brake, 2.5 hp continuous
(Export)	1-Speed, 2.0 hp continuous
Circulation Pump	Yes
Total PowerPro Jets	24
Maxx PowerPro (MX)	N/A
PowerPro (LX)	4
Mini PowerPro (FX)	18
Micro PowerPro (SX)	2
Jet Selectors	1
Air Controls	Three, On / Off Pushbutton Type
Total Foot Jet Therapy	2
Water Management System	Two 60 ft ² Filter Cartridges; Filter 1 on 24-Hour Circulation Pump; Filter 2 on 2-Speed Pump 1; Ready for optional CD Ozone Generator (Factory Installed Ozone Injector And Ozone Dispersion Chamber)
Lighting	One Underwater LED ProLite with 7 Color Modes + Colored Waterfall
Cabinet	Synthetic Cabinet in Harvest Wheat, Autumn Red or Silverwood Color
Acrylic Colors	Textured Bluegrass, Marine, Onyx, Sahara, or Sand; Marbled Platinum, or Solid Azure or Silver
Headrests	4
Waterfall	Includes Flow Rate / On-Off Adjustment; Powered by Pump 1
Electrical Requirements	North American 60 Hz Models: 240 VAC @ 35A, 50A or 60A Export 50 Hz Models: 230-240 VAC @ 20A, 30A or 40A, or suitably rated circuit breaker to comply with local electrical codes. Certain countries may require dual power inputs; two breakers are required for this configuration.
Warranty	North American 60 Hz Models: 10 Years Shell, 7 Years Shell Surface, 5 Years for Plumbing Component Leaks, 5 Years Equipment & Controls; Export 50 Hz Models: 2 Years Plumbing Component Leaks, 2 Years Equipment & Controls
Seating Capacity	5
Audio System (Optional)	AM/FM/CD Stereo Receiver with Dual Pop-Up Speakers And Remote



Dimensions/Specifications are Subject to Change Without Notice



Jacuzzi J-335

Jet Selector / Air Control Diagram

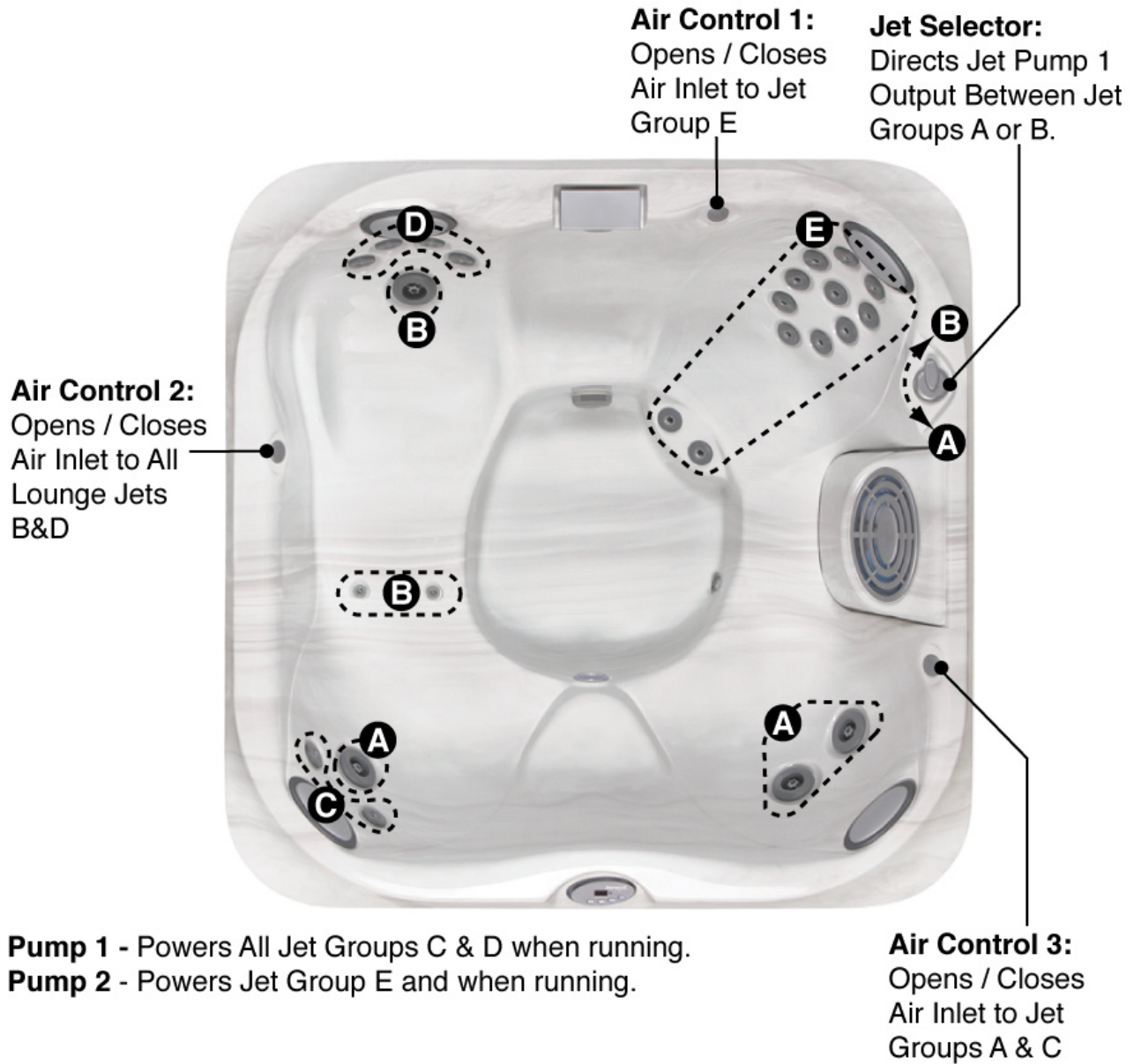

Seat Depths

A = 26.50" (67.3cm)
B = 24.00" (60.1cm)
C = 28.75" (73.0cm)
D = 23.00" (58.4cm)
E = 27.50" (69.9cm)

F = 19.75" (50.2cm)
G = 27.00" (68.6cm)
H = 34.00" (86.4cm)

Listed Dimensions
Represent Distance from
Top of Acrylic to Lowest
Point in Seat.

Dimensions/Specifications Subject to Change Without Notice



Jacuzzi J-325

Dimensions	84" x 76" x 34" (213cm x 193cm x 86cm); For Detailed Dimensions, See Page 26	
Dry Weight	738 lbs (335 kg)	
Filled Weight	3,386 lbs (1,536 kg)	
Water Capacity (Avg. Fill)	320 US gallons (1,211 Liters)	
Electronic Controls	Solid State Electronic Controls with LED Readout, Programmable Temperature, Filtration, and Heat Cycles	
Pump 1 (North American)	2-Speed, 4.0 hp brake, 2.5 hp continuous (Export) 2-Speed, 2.0 hp continuous	
Circulation Pump	Yes	
Total PowerPro Jets	15	
Maxx PowerPro (MX)	N/A	
PowerPro (LX)	11	
Mini PowerPro (FX)	4	
Micro PowerPro (SX)	N/A	
Jet Selectors	1	
Air Controls	Three, On / Off Pushbutton Type	
Total Foot Jet Therapy	2	
Water Management System	Two 60 ft ² Filter Cartridges; Filter 1 on 24-Hour Circulation Pump; Filter 2 on 2-Speed Pump 1; Ready for optional CD Ozone Generator (Factory Installed Ozone Injector And Ozone Dispersion Chamber)	
Lighting	One Underwater LED ProLite with 7 Color Modes + Colored Waterfall	
Cabinet	Synthetic Cabinet in Harvest Wheat, Autumn Red or Silverwood Color	
Acrylic Colors	Textured Bluegrass, Marine, Onyx, Sahara, or Sand; Marbled Platinum, or Solid Azure or Silver	
Headrests	4	
Waterfall	Includes Flow Rate / On-Off Adjustment; Powered by Pump 1	
Electrical Requirements	North American 60 Hz Models: 240 VAC @ 35A or 50A, Export 50 Hz Models: 230-240 VAC @ 20A or 30A, or suitably rated circuit breaker to comply with local electrical codes. Certain countries may require dual power inputs; two breakers are required for this configuration.	
Warranty	North American 60 Hz Models: 10 Years Shell, 7 Years Shell Surface, 5 Years for Plumbing Component Leaks, 5 Years Equipment & Controls; Export 50 Hz Models: 2 Years Plumbing Component Leaks, 2 Years Equipment & Controls	
Seating Capacity	4	
Audio System (Optional)	N/A	

Dimensions/Specifications Subject to Change Without Notice



Jacuzzi J-325

Jet Selector / Air Control Diagram

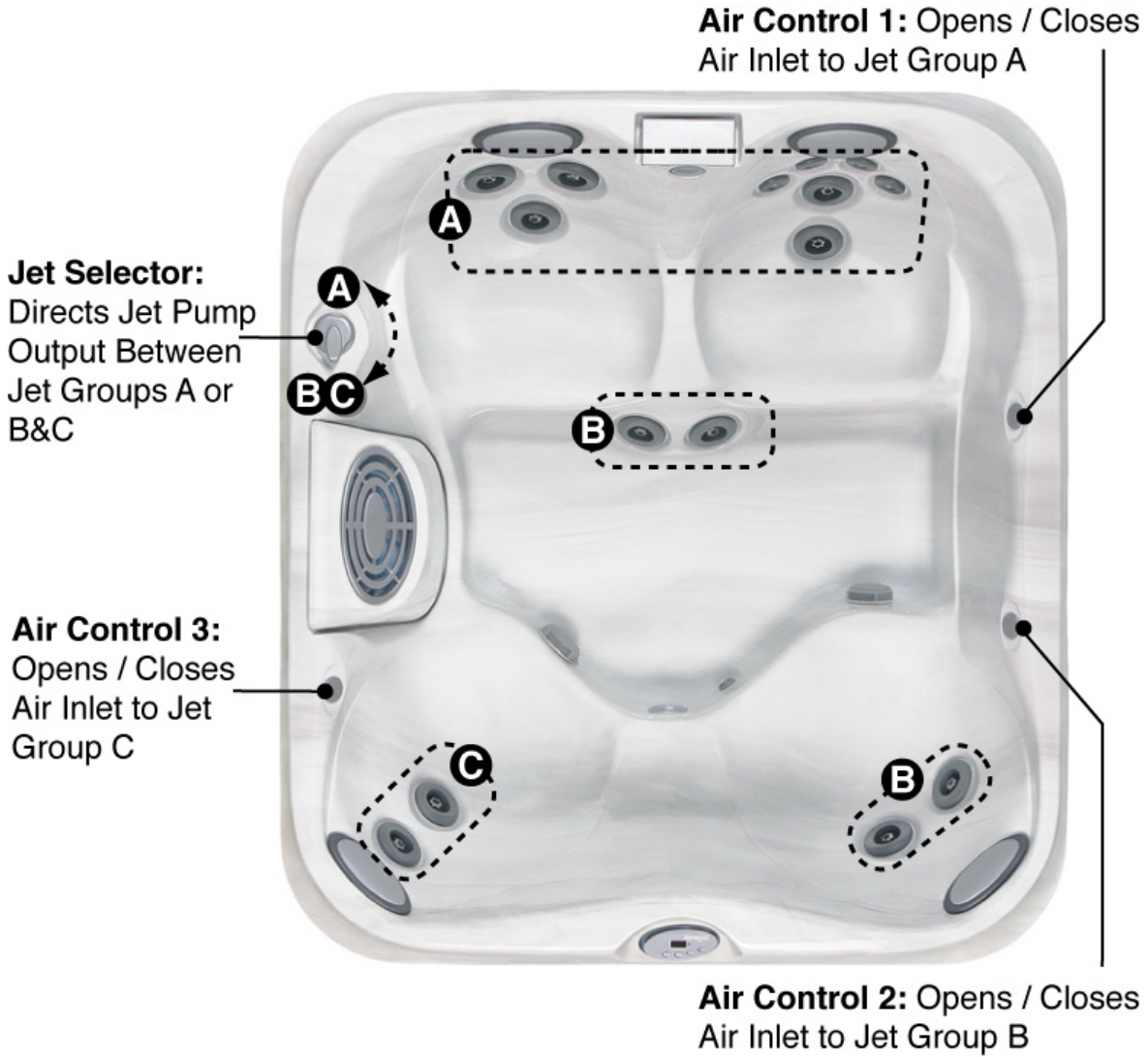

Seat Depths

- A = 27.00" (68.6cm)
- B = 27.25" (69.2cm)
- C = 25.75" (65.4cm)
- D = 21.50" (54.6cm)
- E = 28.00" (71.1cm)
- F = 31.25" (79.4cm)

Listed Dimensions Represent Distance from Top of Acrylic to Lowest Point in Seat.



Dimensions/Specifications Subject to Change Without Notice

Jacuzzi J-315

Dimensions	76" x 66" x 32" (193cm x 168cm x 81cm); For Detailed Dimensions, See Page 26	
Dry Weight	640 lbs (290 kg)	
Filled Weight	2,283 lbs (1036 kg)	
Water Capacity (Avg. Fill)	200 US gallons (757 Liters)	
Electronic Controls	Solid State Electronic Controls with LED Readout, Programmable Temperature, Filtration, and Heat Cycles	
Pump 1 (North American)	2-Speed, 2.0 hp brake, 1.5 hp continuous	
(Export)	2-Speed, 2.0 hp continuous	
Circulation Pump	Yes	
Total PowerPro Jets	13	
Maxx PowerPro (MX)	N/A	
PowerPro (LX)	7	
Mini PowerPro (FX)	6	
Micro PowerPro (SX)	N/A	
Jet Selectors	1	
Air Controls	Two, On / Off Pushbutton Type	
Total Foot Jet Therapy	2	
Water Management System	Two 60 ft ² Filter Cartridges; Filter 1 on 24-Hour Circulation Pump; Filter 2 on 2-Speed Pump 1; Ready for optional CD Ozone Generator (Factory Installed Ozone Injector And Ozone Dispersion Chamber)	
Lighting	One Underwater LED ProLite with 7 Color Modes + Colored Waterfall	
Cabinet	Synthetic Cabinet in Harvest Wheat, Autumn Red or Silverwood Color	
Acrylic Colors	Textured Bluegrass, Marine, Onyx, Sahara, or Sand; Marbled Platinum, or Solid Azure or Silver	
Headrests	3	
Waterfall	Includes Flow Rate / On-Off Adjustment; Powered by Pump 1	
Electrical Requirements	North American 60 Hz Models: 120 VAC @ 15A or 240 VAC @ 30A or 40A, Export 50Hz Models: 230-240 VAC @ 20A or 30A, or suitably rated circuit breaker to comply with local electrical codes. Certain countries may require dual power inputs; two breakers are required for this configuration.	
Warranty	North American 60 Hz Models: 10 Years Shell, 7 Years Shell Surface, 5 Years for Plumbing Component Leaks, 5 Years Equipment & Controls; Export 50 Hz Models: 2 Years Plumbing Component Leaks, 2 Years Equipment & Controls	
Seating Capacity	3	
Audio System (Optional)	N/A	

Dimensions/Specifications are Subject to Change Without Notice



Jacuzzi J-315

Jet Selector / Air Control Diagram

Jet Selector:
Directs Jet Pump
Output Between
Jet Groups A or B

Air Control 1:
Opens / Closes
Air Inlet to Jet
Group A



Air Control 2:
Opens / Closes
Air Inlet to Jet
Group B

Seat Depths

- A = 26.50" (67.3cm)
- B = 28.00" (71.1cm)
- C = 27.00" (68.6cm)
- D = 28.00" (71.1cm)
- E = 27.75" (70.5cm)

Listed Dimensions
Represent Distance from
Top of Acrylic to Lowest
Point in Seat.



Dimensions/Specifications Subject to Change Without Notice

Jacuzzi J-230

Dimensions	84" x 84" x 36" (213.4cm x 213.4cm x 91.4 cm); For Detailed Dimensions, See Page 27	
Dry Weight	630 lbs (285.8 kg)	
Filled Weight	3,799 lbs (1723.2 kg)	
Water Capacity (Avg. Fill)	340 US gallons (1287.1 Liters)	
Electronic Controls	Solid State Electronic Controls with LED Readout, Programmable Temperature, Filtration, and Heat Cycles	
Pump 1 (North American)	2-Speed, 4.2 hp brake, 2.5 hp continuous	
Pump 2 (North American)	1-Speed, 4.2 hp brake, 2.5 hp continuous	
Pump 1 (Export)	2-Speed, 3.5 hp brake, 2.0 hp continuous	
Pump 2 (Export)	2-Speed, 3.5 hp brake, 2.0 hp continuous	
Circulation Pump	No	
Total Jets	33	
Euro Jets	6	
Micro Jets	20	
Luxury Jets	3	
Pulsator Jets	4	
Air Controls	2	
Total Foot Jet Therapy	2	
Water Management System	One 50 ft ² Filter Cartridge (Models Manufactured After August 10, 2005 Are Ozone Ready for Optional Ozone Generator And Include a Factory Installed Ozone Injector)	
Lighting	Underwater with Two Colored Lenses; Optional Underwater Plug-in Multi-Color LED Light	
Cabinet	Synthetic Cabinet in Autumn Red Only	
Acrylic Colors	Textured Marine, Sahara, or Marbled Platinum	
Headrests	3	
Electrical Requirements	North American 60Hz Models: 240 VAC @ 35A or 50A, Export 50Hz Models: 230 VAC @ 20A or 30A, or suitably rated circuit breaker to comply with local electrical codes. Certain countries may require dual power inputs; two breakers are required for this configuration.	
Warranty	(Manufacture Date of 01/05-04/05) North American 60Hz Models: 5 Years Shell, 3 Years Shell Surface, 1 Years for Plumbing Component Leaks, 1 Year Equipment & Controls; Export 50Hz Models: 5 Years Shell, 3 Years Shell Surface, 1 Years for Plumbing Component Leaks, 1 Year Equipment & Controls;	
Warranty	(Manufacture Date of 05/05+) North American 60Hz Models: 5 Years Shell, 3 Years Shell Surface, 3 Years for Plumbing Component Leaks, 3 Years Equipment & Controls; Export 50Hz Models: 5 Years Shell, 3 Years Shell Surface, 1 Years for Plumbing Component Leaks, 1 Year Equipment & Controls	
Seating Capacity	5	
Audio System (Optional)	N/A	

Dimensions/Specifications are Subject to Change Without Notice



Jacuzzi J-230

Jet Selector / Air Control Diagram



**Jets Groups A Powered by Jets Pump 1.
Jets Groups B Powered by Jets Pump 2.**

Seat Depths

- A = 28.0" (71.1cm)
- B = 26.5" (67.3cm)
- C = 26.5" (67.3cm)
- D = 26.0" (66.0cm)
- E = 33.0" (83.8cm)

*Listed Dimensions
Represent Distance from
Top of Acrylic to Lowest
Point in Seat.*

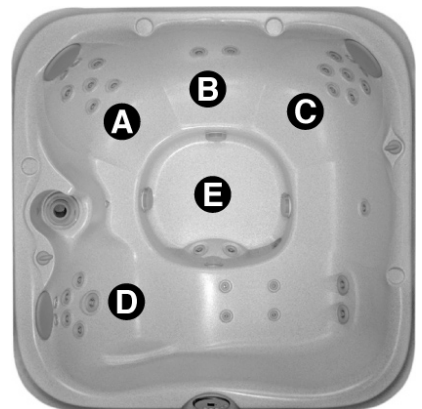

Jacuzzi J-220

Dimensions	76" x 84" x 36" (193.0cm x 213.4cm x 91.4 cm); For Detailed Dimensions, See Page 27	
Dry Weight	530 lbs (240.4 kg)	
Filled Weight	3,324lbs (1507.7 kg)	
Water Capacity (Avg. Fill)	335 US gallons (1268.1 Liters)	
Electronic Controls	Solid State Electronic Controls with LED Readout, Programmable Temperature, Filtration, and Heat Cycles	
Pump (North American)	2-Speed, 2.0 hp brake, 1.5 hp continuous	
Pump (Export)	2-Speed, 3.5 hp brake, 2.0 hp continuous	
Circulation Pump	No	
Total Jets	21	
Euro Jets	4	
Micro Jets	15	
Luxury Jets	2	
Jet Selectors	1	
Air Controls	3	
Total Foot Jet Therapy	2	
Water Management System	One 50 ft ² Filter Cartridge (Models Manufactured After August 10, 2005 Are Ozone Ready for Optional Ozone Generator And Include a Factory Installed Ozone Injector)	
Lighting	Underwater with Two Colored Lenses; Optional Underwater Plug-in Multi-Color LED Light	
Cabinet	Synthetic Cabinet in Autumn Red Only	
Acrylic Colors	Textured Marine, Sahara, or Marbled Platinum	
Headrests	2	
Electrical Requirements	North American 60 Hz Models: 120 VAC @ 15A or 240 VAC @ 30A or 40A, Export 50Hz Models: 230 VAC @ 20A or 30A, or suitably rated circuit breaker to comply with local electrical codes. Certain countries may require dual power inputs; two breakers are required for this configuration.	
Warranty	(Manufacture Date of 01/05-04/05) North American 60Hz Models: 5 Years Shell, 3 Years Shell Surface, 1 Years for Plumbing Component Leaks, 1 Year Equipment & Controls; Export 50Hz Models: 5 Years Shell, 3 Years Shell Surface, 1 Years for Plumbing Component Leaks, 1 Year Equipment & Controls;	
Warranty	(Manufacture Date of 05/05+) North American 60Hz Models: 5 Years Shell, 3 Years Shell Surface, 3 Years for Plumbing Component Leaks, 3 Years Equipment & Controls; Export 50Hz Models: 5 Years Shell, 3 Years Shell Surface, 1 Years for Plumbing Component Leaks, 1 Year Equipment & Controls	
Seating Capacity	4	
Audio System (Optional)	N/A	

Dimensions/Specifications are Subject to Change Without Notice



Jacuzzi J-220

Jet Selector / Air Control Diagram

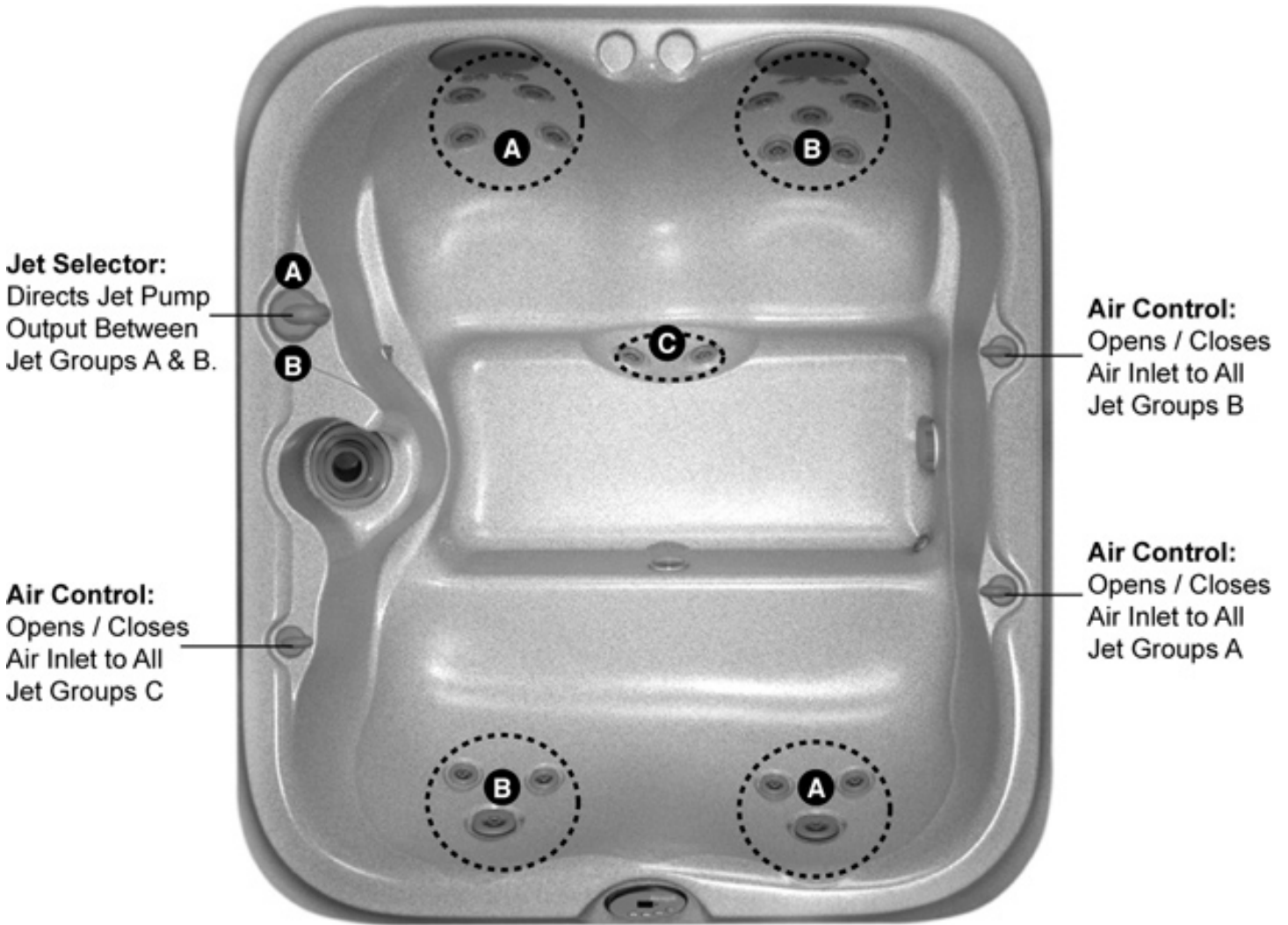

Jets C Powered Continuously When Jets Pump is Running.

Seat Depths

- A = 27.0" (68.6cm)
- B = 31.3" (79.4cm)
- C = 24.5" (62.2cm)

Listed Dimensions Represent Distance from Top of Acrylic to Lowest Point in Seat.

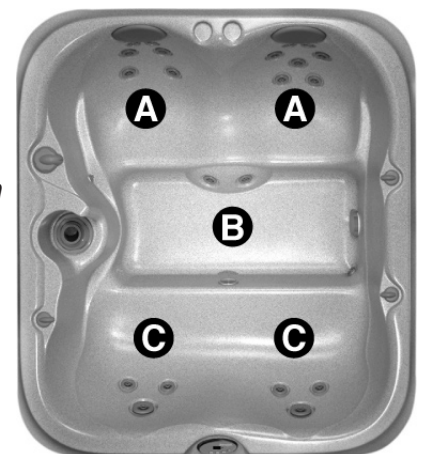

Dimensions/Specifications Subject to Change Without Notice

Jacuzzi J-210

Dimenons	78" Round x 36" Deep (198.1cm Round x 914.4cm Deep); For Detailed Dimensions, See Page 27	
Dry Weight	410 lbs (186.0 kg)	
Filled Weight	2245 lbs (1018.3 kg)	
Water Capacity (Avg. Fill)	220 US gallons (832.8 Liters)	
Electronic Controls	Solid State Electronic Controls with LED Readout, Programmable Temperature, Filtration, and Heat Cycles	
Pump (North American)	2-Speed, 2.0 hp brake, 1.5 hp continuous	
Pump (Export)	2-Speed, 3.5 hp brake, 2.0 hp continuous	
Circulation Pump	No	
Total Jets	19	
Euro Jets	4	
Micro Jets	10	
Luxury Jets	4	
Divert-A-Jet	1	
Air Controls	3	
Total Foot Jet Therapy	2	
Water Management System	One 50 ft ² Filter Cartridge; Ready for optional CD Ozone Generator (Models Manufactured After August 10, 2005 Are Ozone Ready And Include a Factory Installed Ozone Injector)	
Lighting	Underwater with Two Colored Lenses; Optional Underwater Plug-in Multi-Color LED Light	
Cabinet	Synthetic Cabinet in Autumn Red Only	
Acrylic Colors	Textured Marine, Sahara, or Marbled Platinum	
Electrical Requirements	North American 60 Hz Models: 120 VAC @ 15A or 240 VAC @ 30A or 40A, Export 50Hz Models: 230 VAC @ 20A or 30A, or suitably rated circuit breaker to comply with local electrical codes. Certain countries may require dual power inputs; two breakers are required for this configuration.	
Warranty	(Manufacture Date of 01/05-04/05) North American 60Hz Models: 5 Years Shell, 3 Years Shell Surface, 1 Years for Plumbing Component Leaks, 1 Year Equipment & Controls; Export 50Hz Models: 5 Years Shell, 3 Years Shell Surface, 1 Years for Plumbing Component Leaks, 1 Year Equipment & Controls;	
Warranty	(Manufacture Date of 05/05+) North American 60Hz Models: 5 Years Shell, 3 Years Shell Surface, 3 Years for Plumbing Component Leaks, 3 Years Equipment & Controls; Export 50Hz Models: 5 Years Shell, 3 Years Shell Surface, 1 Years for Plumbing Component Leaks, 1 Year Equipment & Controls	
Seating Capacity	4	
Audio System (Optional)	N/A	

Dimensions/Specifications are Subject to Change Without Notice



Jacuzzi J-210

Jet Selector / Air Control Diagram

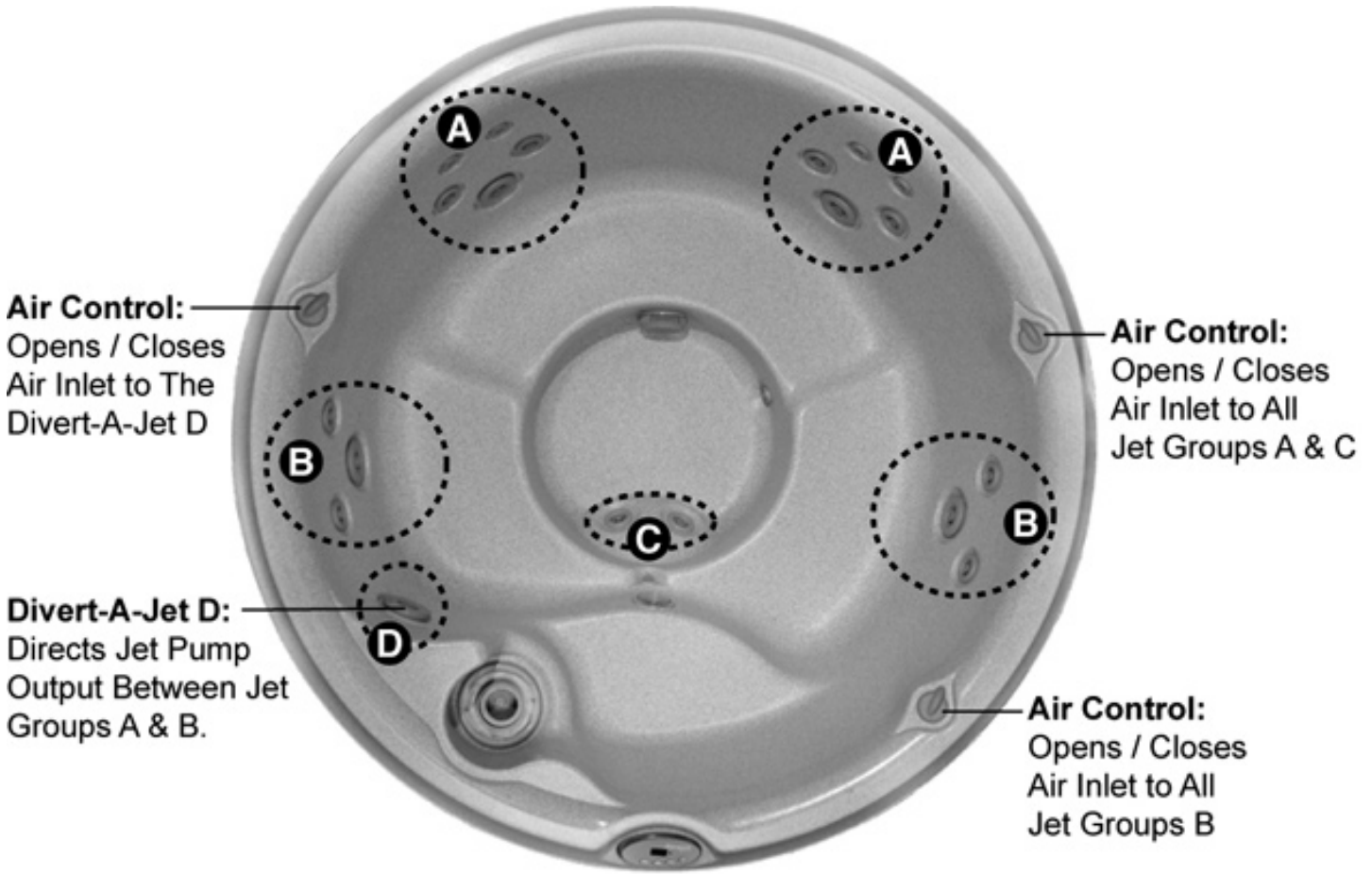

Jets C Powered Continuously When Jets Pump is Running.

Seat Depths

- A = 27.0" (68.6cm)
- B = 24.5" (62.2cm)
- C = 16.5" (41.9cm)
- D = 24.5" (62.2cm)
- E = 34.0" (86.4cm)

Listed Dimensions
Represent Distance from
Top of Acrylic to Lowest
Point in Seat.

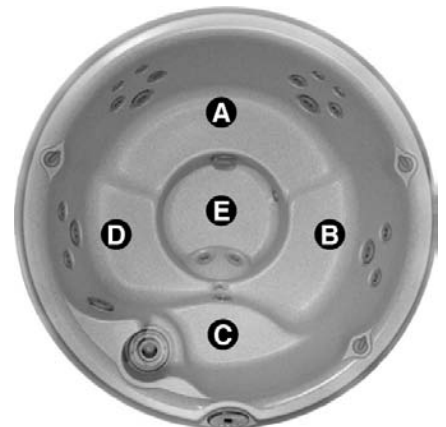

Dimensions/Specifications Subject to Change Without Notice



Detailed Dimensions - All 300 Series Models

SPA MODEL	DIMENSIONS A - F					
	A	B	C	D	E	F
J-385	94" (238.8cm)	94" (238.8cm)	31.75" (80.6cm)	38" (96.5cm)	66.75" (169.5cm)	67.50" (171.5cm)
J-375	91" (231.1cm)	91" (231.1cm)			64.50" (163.8cm)	64.50" (163.8cm)
J-365	84" (213.4cm)	84" (231.1cm)	30.00" (76.2cm)	36" (91.4cm)	57.50" (146.1cm)	57.50" (146.1cm)
J-355			29.75" (75.6cm)			
J-345		28.00" (71.1cm)	34" (86.4cm)	50.25" (127.6cm)	57.38" (145.7cm)	
J-325		26.00" (66.0cm)	32" (81.3cm)	49.63" (126.1cm)	39.63" (100.7cm)	
J-315	66" (167.6cm)	76" (193.0cm)	26.00" (66.0cm)	32" (81.3cm)	49.63" (126.1cm)	39.63" (100.7cm)
DIMENSIONS G - L						
	G	H	I	J	K	L
J-385	N/A	N/A	38.00" (96.5cm)	5.00" (12.7cm)	16.5" (41.6cm)	2.75" (6.9cm)
J-375			32.50" (82.6cm)	7.00" (17.8cm)		
J-365			34.50" (87.6cm)	8.00" (20.3cm)		
J-355			37.50" (95.3cm)	10.00" (25.4cm)		
J-345			32.50" (82.6cm)	8.00" (20.3cm)		
J-335	28.00" (71.1cm)	5.50" (14.0cm)	N/A	N/A	N/A	N/A
J-325	N/A	N/A	28.00" (71.1cm)	6.00" (15.2cm)		
J-315	34.00" (86.4cm)	9.00" (22.9cm)	N/A	N/A		

- Dimensions Subject to Change Without Notice -

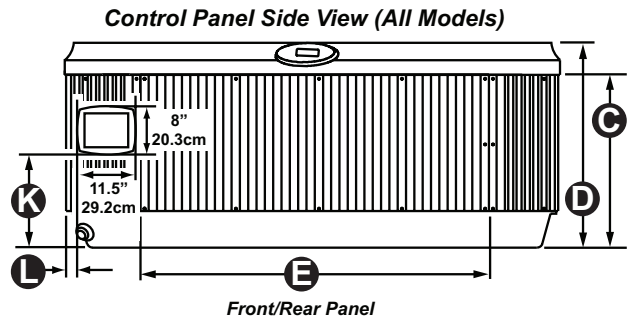
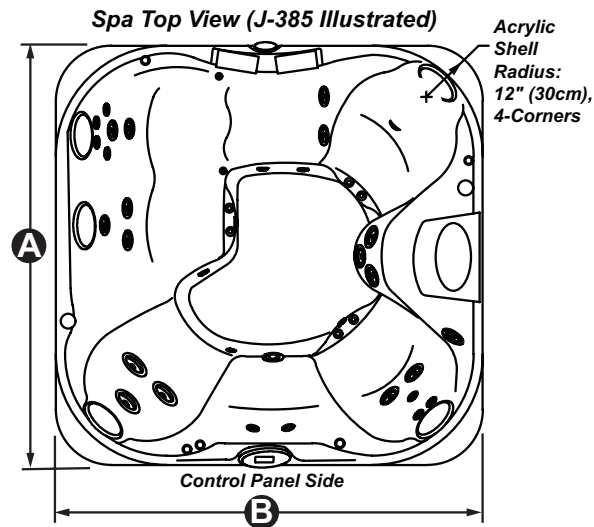

IMPORTANT! Always Measure Each Hot Tub for Exact Dimensions BEFORE Designing its Foundation Support and/or Decking.

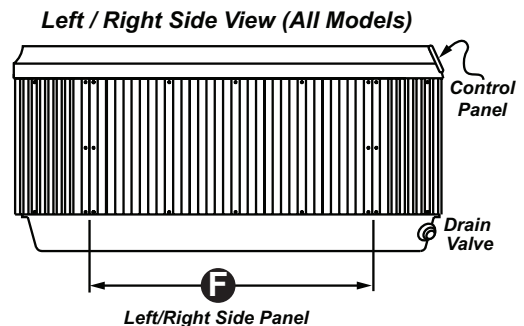
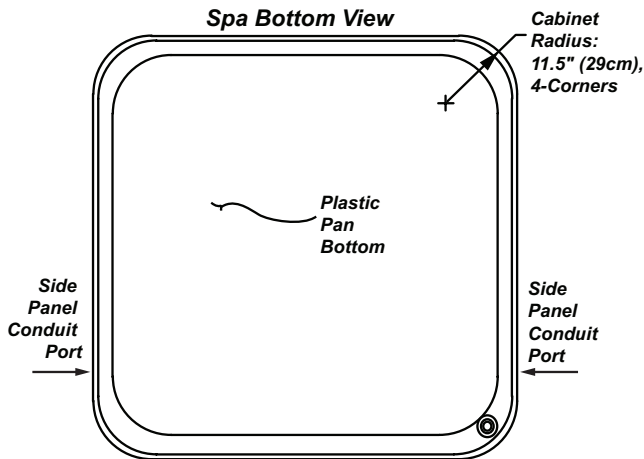
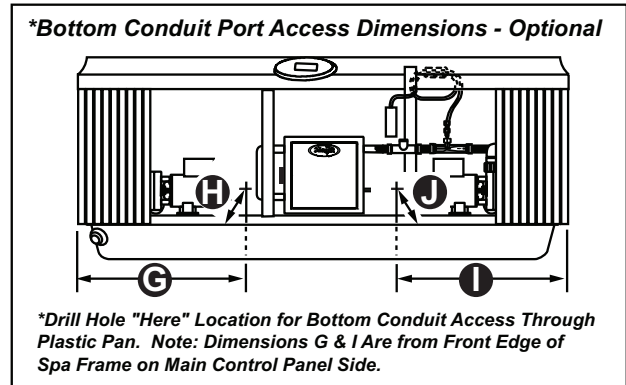

Note: Gaps in underlying wood frame are for ventilation purposes; not for electrical hook-ups or other uses.



Detailed Dimensions - All 200 Series Models

SPA MODEL	DIMENSIONS A - F					
	A	B	C	D	E	F
J-210 (Round Spa)	78" (198.1cm) Round		30" (76.2cm)	36" (91.4cm)	77.25" (196.2cm) Round	
J-220 (Rectangular Spa)	84" (213.4cm)	76" (193.0cm)			75.25" (191.1cm)	83.25" (211.5cm)
J-230 (Square Spa)	84" (213.4cm) Square				83.25" (211.4cm) Square	

- Dimensions Subject to Change Without Notice -

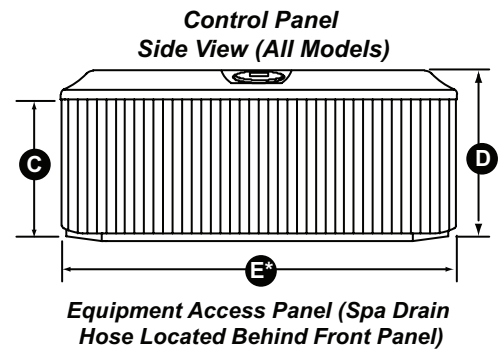
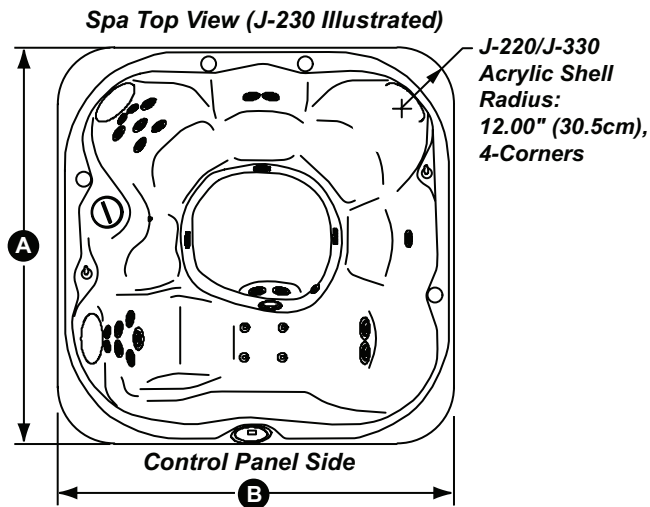

IMPORTANT! Always Measure Each Hot Tub for Exact Dimensions **BEFORE** Designing its Foundation Support and/or Decking.

*Panels E & F: Always Design Surround or Decking to Allow Removal of Entire Side Skirt on All Sides of Spa for Drain / Repair Access.

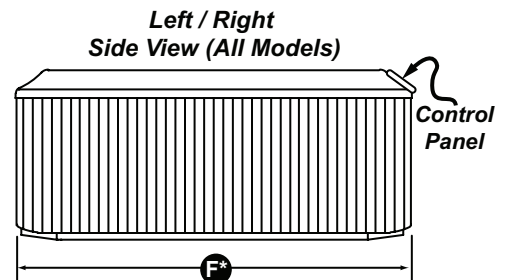
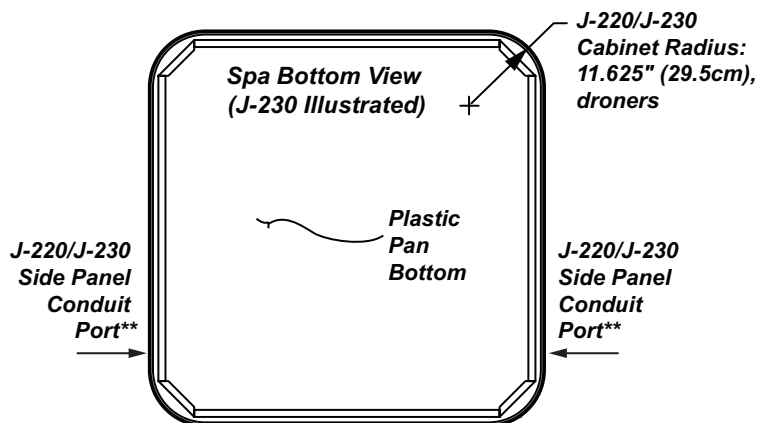

**Single Conduit Port Available on Round J-210 Models at Front Panel Side of Spa.

Note: Gaps in underlying wood frame are for ventilation purposes; not for electrical hook-ups or other uses.

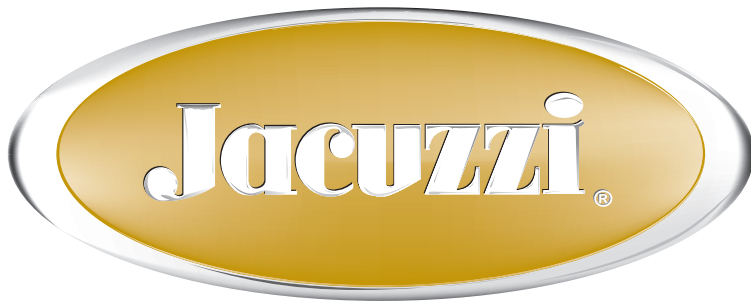

Hot Tubs

14525 Monte Vista Ave. • Chino, CA 91710
Website: <http://www.jacuzzipremium-dealers.com>